

# MiTek<sup>®</sup> POSI-STRUT<sup>®</sup> CATALOGUE



## THE MITEK POSI-STRUT ENGINEERED SYSTEM

MiTek ensures that regional manufacturers meet the highest standards for the production of our Posi-Strut product. From training production crews, technical and sales teams to approval of design drawings, you can count on MiTek.

## QUALITY COMPONENTS

Our G90 galvanized steel structural webs and connectors are produced at our MiTek stamping plant in Bradford, Ontario.

## PRODUCED BY AUTHORIZED MANUFACTURERS

The Posi-Strut Engineered System is produced by manufacturers across Canada, licenced by MiTek.

## TRAINING

MiTek's multidisciplinary team provides training for the manufacturer's production crew, technicians, sales and / or engineers on the various aspects of Posi-Strut truss design and fabrication. From plant layout planning, training on our design software, to quality control, MiTek ensures that everything is done to produce a consistently high-quality product, that will ensure your satisfaction.

## DESIGN SOFTWARE

All Posi-Struts are designed using our world-class 3D / BIM software suite. Each project is modelled, then each component is properly analyzed and optimized to meet the requirements of the project. Every Posi-Strut truss is custom-designed specifically for your project, or can be designed allowing for on-site flexibility by utilizing trimmable ends.

## REVIEW AND APPROVAL OF THE DRAWINGS

MiTek provides professional engineering services for the floor systems produced. Depending on the requirements of the project, design drawings can be reviewed and sealed by one of MiTek's professional engineers.

## QUALITY CONTROL

Posi-Strut manufacturers must follow MiTek's Quality Control manual and manufacturing processes. Various manufacturing tolerances are pre-defined as part of the manufacturer's quality assurance program.

## TECHNICAL ASSISTANCE

MiTek works in partnership with the component manufacturer, providing information, knowledge and resources. Our experienced team is available to answer your questions. You can reach us at 1-800-268-3434 or by email at [Posi-Strut@mitek.ca](mailto:Posi-Strut@mitek.ca).

## FREE SAPPHIRE VIEWER APP

Would you like to see your project in 3D on your tablet or mobile phone? Simply download the Sapphire Viewer app from the Apple App Store, Android Store or Google Play Store. The 3D virtual model can be shared by the manufacturer with various parties downstream in the supply chain as well as site crews to ensure better collaboration and planning. Look at cross-sections, walk through the model and visualize your project with our 3D app. A PC version of the application is also available.

For more details, please visit our website at: [www.mitek.ca](http://www.mitek.ca).

Our core purpose is to **create breakthroughs** in building  
that **accelerate** the **GENIUS** of our customers.

Certifications and Evaluation Reports . . . . .	3
Features and Benefits . . . . .	4
Product Physical Properties . . . . .	5
Ductwork Dimensions . . . . .	6
Floor Performance . . . . .	7
Span Tables . . . . .	8
Design Hints . . . . .	12
Typical Engineering Report. . . . .	13
Bottom Chord Bearing Details . . . . .	14
Cantilever Details. . . . .	15
Top Chord Bearing Details . . . . .	16
Adjustable End Details . . . . .	16
Mid-Span Bearing Details . . . . .	17
Multi-Level Assembly Details. . . . .	18
Vertical Load Transfer . . . . .	19
Staircase Assembly Details . . . . .	20
Strongbacks . . . . .	22
Double Ply Floor Girder Assembly. . . . .	23
Fire and Sound Certified Assemblies . . . . .	24

**POSI-STRUT IS ALSO USED  
 IN OTHER COUNTRIES  
 AROUND THE WORLD**



Canadian Construction Materials Centre  
 Report number: **CCMC 12691**



ICC-ES US  
 Report number: **ER-3907**



## CUSTOM DESIGNED AND PRECISELY ENGINEERED

Each Posi-Strut is custom-designed to your specific project using MiTek's state-of-the-art BIM design software. The system is manufactured to precise engineering specifications, delivering reliable performance. Because the Posi-Strut floor is custom-built for your project, there is no need to cut the structural elements on-site and the chance of on-site theft is greatly reduced.

## OPEN WEB DESIGN

An open web design eliminates the need for cutting and drilling. Plumbing, electrical and ventilation services can be quickly installed and concealed in the floor cavity, saving time and money. The ability to conceal services also helps eliminate concerns of reduced ceiling heights, adding bulkheads, modifying structural elements or costly site repairs. Posi-Strut trusses can accommodate larger utility openings in comparison to any other floor system of the same depth.



## LONGER CLEAR SPANS

Posi-Strut trusses can help eliminate interior load-bearing walls and/or beams. With longer clear spans than conventional lumber, architects and engineers can now enjoy clear span flexibility and building design freedom. Posi-Strut's unique design allows for shallower-depth floors, contributing to overall building cost savings.

## WIDE NAILING SURFACE

The Posi-Strut truss has a wide nailing surface that speeds up installation of the structural elements and floor sheathing. The wide 2.5" or 3.5" flange width provides a large surface for application of the subfloor adhesive, contributing to easier installation of the floor sheathing. Ceiling materials can also be easily fixed to the underside of the Posi-Strut truss bottom chords.



## LIGHTWEIGHT

Mainly produced with 3x2 or 4x2 chords, in combination with our Posi-Strut webs, the Posi-Strut engineered floor system has a very high strength-to-weight ratio, making it one of the lightest engineered wood products in the industry as well as one that is easy to handle and install.

## TOP CHORD BEARING

Arguably one of the most recognized features of the Posi-Strut open web floor system is its capacity to hide beams in the floor cavity by using a pre-engineered top chord bearing end detail. No joist hangers are necessary, resulting in substantial material and labour savings.



## STRONGBACK BRIDGING

Posi-Strut's open concept allows for installation of strongback bridging, which actively contributes to the reduction of floor vibrations. The addition of this important structural element enables the individual Posi-Strut trusses to work together as a floor 'system'. The quantity, size, location and connection of the strongbacks can be customized to suit the requirements of each project. Strongback information is indicated on the design / shop drawings of the Posi-Strut trusses and installation guide, and may also be included on the floor framing plan.

## TRIMMABLE ENDS ENSURE A PERFECT FIT

The Posi-Strut floor system can also be designed with flexibility in mind, utilizing pre-engineered trimmable-end details for projects where dimensional precision cannot be achieved until after framing has commenced. Our site-adjustable trim end details eliminate headaches due to bearing location discrepancies or design changes. Since Posi-Strut allows for both precise design as well as optional trimmable ends, you know that you can count on installing a highly versatile and efficient floor system.



## SAFETY

The performance of Posi-Strut in load and fire tests shows great safety margins. Also, non-combustible, galvanized steel diagonals reduce the amount of combustible materials in the event of fire.

## FIRE RATINGS

Posi-Strut has different fire-rated assemblies to suit your project needs and building code requirements. A complete list of Intertek certified fire-rated assemblies which meet CAN/ULC-S101 and ASTM-E119 standards for 45, 60 and 90-minute requirements are available on pages 24 to 35.

## SOUND RATINGS

Posi-Strut has certified assemblies ranging from 50–57 in sound transmission class ratings for different sound requirements. Please refer to the available Intertek certified assemblies for details, or contact us and we will gladly help you. A complete list of certified assemblies are available on pages 24 to 35.

## SAVINGS

Posi-Strut practically eliminates waste on the job site compared to conventional sawn lumber and other floor products. The open web cavities reduce additional labour costs for installing electrical, plumbing and HVAC services, eliminating the need for additional costly bulkheads. The longer clear spans of Posi-Strut, alongside its various end details can help eliminate additional structural elements such as columns, beams, rimboard and hangers.

## BUILD FASTER

The ready-to-install Posi-Strut system saves time and labour while preventing errors or compromising structural integrity due to improper on-site cutting.

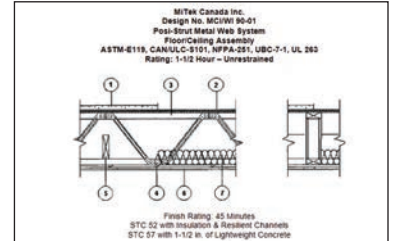

## Product Physical Properties

### LUMBER

Posi-Strut is typically produced from 3x2 and 4x2 (2x3 and 2x4 flat-oriented) kiln-dried lumber that has been graded for use in Canada, according to the National Lumber Grades Authority (NLGA) grading rules. Posi-Strut trusses can be manufactured using visually graded or Machine Stress-Rated (MSR) lumber. MSR lumber differs from visually graded lumber in that each piece is non-destructively evaluated by mechanical stress-rating equipment, to assign a strength capacity to the lumber.

### METAL WEBS

Posi-Strut's patented metal webs are produced in six (6) depths using non-combustible, 20-gauge G90 galvanized, renewable steel. The G90 galvanization ensures long lasting performance and protection during construction.

### AVAILABLE DEPTHS

Product	Depth
PS-10v2	9 1/4"
PS-12	11 1/4"
PS-12I	11 7/8"
PS-13	12 3/4"
PS-14V3	14"
PS-16V3	16"

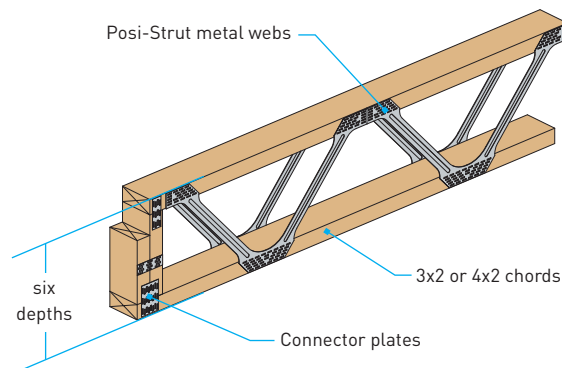

The table below indicates standard ductwork clearances for the Posi-Strut system. For alternate ductwork clearances or chase openings other than those shown here, please contact your Posi-Strut manufacturer to inquire about customizing clearances for your specific project.

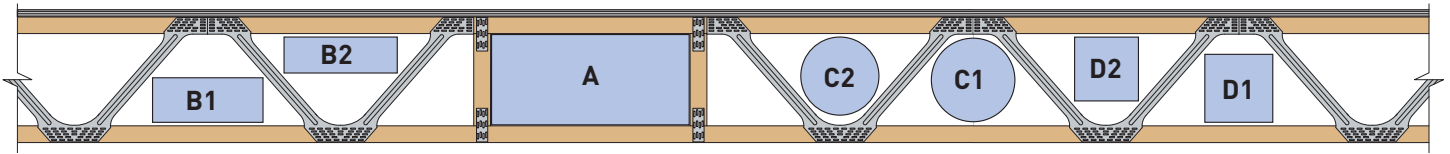

RECTANGULAR <b>A</b>	CHASE OPENING					
	PS-10v2	PS-12	PS-12I	PS-13	PS-14v3	PS-16v3
	MAXIMUM SIZE					
MAX	6 1/4 X 24	8 1/4 X 24	9 7/8 X 24	9 3/4 X 24	11 X 24	13 X 24

CIRCULAR <b>C1</b>	BOTTOM CHORD					
	PS-10v2	PS-12	PS-12I	PS-13	PS-14v3	PS-16v3
	MAXIMUM DIAMETER					
MAX	6	8	8-1/2	9-1/16	10	11-1/4

RECTANGULAR <b>B1</b>	BOTTOM CHORD					
	PS-10v2	PS-12	PS-12I	PS-13	PS-14v3	PS-16v3
DEPTHS	MAXIMUM LENGTHS					
2.25	12-7/16	13-13/16	14-15/16	16-7/16	18-5/8	19-5/16
3	10-13/16	12-1/2	13-5/8	15-1/8	17-5/16	18-3/16
3.25	10-5/16	12-1/16	13-3/8	14-11/16	16-7/8	17-13/16
4	8-3/4	10-3/4	11-13/16	13-3/8	15-9/16	16-5/8
5	6-5/8	9	10-1/16	11-5/8	13-13/16	15-3/16
6	NA	NA	8-5/16	9-7/8	12-1/16	13-11/16
8	NA	NA	NA	NA	8-1/2	10-5/8
10	NA	NA	NA	NA	NA	NA

CIRCULAR <b>C2</b>	TOP CHORD					
	PS-10v2	PS-12	PS-12I	PS-13	PS-14v3	PS-16v3
	MAXIMUM DIAMETER					
MAX	6	7-7/16	7-7/8	8-5/8	9-5/8	10-3/8

SQUARE <b>D1</b>	BOTTOM CHORD					
	PS-10v2	PS-12	PS-12I	PS-13	PS-14v3	PS-16v3
	MAXIMUM SIZE					
MAX	5-1/4	6-1/4	6-3/4	7-1/4	8-1/4	9

RECTANGULAR <b>B2</b>	TOP CHORD					
	PS-10v2	PS-12	PS-12I	PS-13	PS-14v3	PS-16v3
DEPTHS	MAXIMUM LENGTHS					
2.25	11-3/16	12-9/16	13-11/16	15-3/16	17-3/8	17-9/16
3	9-9/16	11-1/4	12-5/16	13-7/8	16-1/16	16-7/16
3.25	9-1/16	10-13/16	11-7/8	13-7/16	15-5/8	16-1/16
4	7-1/2	9-1/2	10-9/16	12-1/8	14-5/16	14-15/16
5	5-3/8	7-3/4	8-13/16	10-3/8	12-9/16	13-7/16
6	NA	NA	7-1/16	8-5/8	10-13/16	11-15/16
8	NA	NA	NA	NA	NA	8-7/8
10	NA	NA	NA	NA	NA	NA

SQUARE <b>D2</b>	TOP CHORD					
	PS-10v2	PS-12	PS-12I	PS-13	PS-14v3	PS-16v3
	MAXIMUM SIZE					
MAX	5	6	6-1/4	6-3/4	7-3/4	8-1/4

1. Dimensions specified in table A are in inches and based on NET dimensions.
2. Dimensions specified in tables B, C and D are in inches and based on a 1/8" clearance.
3. Please make sure to inform and confirm with the Posi-Strut manufacturer, the dimensions of the duct sections (for the chase opening in table A), prior to the design stage. This will help them recommend the best floor depth to accommodate your needs.

**DO NOT CUT, DRILL INTO, OR ALTER THE POSI-STRUT COMPONENTS, NOR CUT NOTCHES IN THE STRONGBACKS**

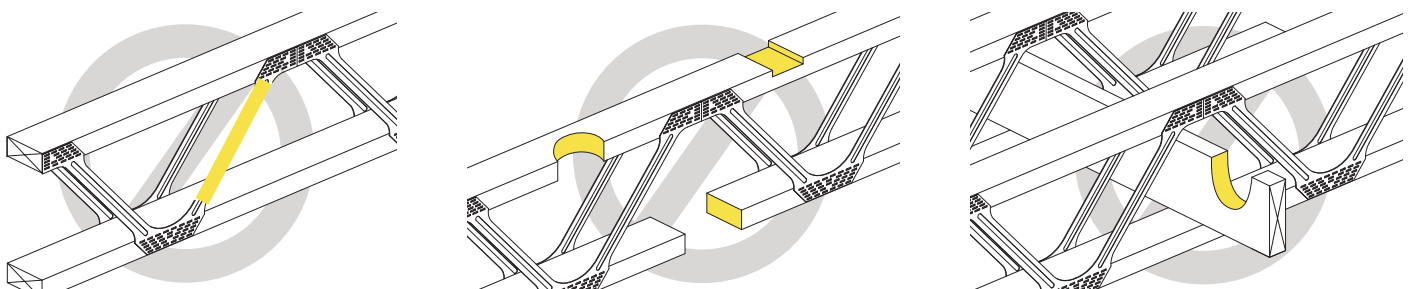

Floor performance is subjective. The dynamic response of floor systems to foot traffic and other non-static loads is dependent on many factors such as the floor plan of supporting walls, interior partitions, furniture layout, etc. The comfort and expectations of occupants also vary widely and are subjective. For some, a code-designed floor would be perfectly fine, while that same floor's performance might be unacceptable to another person. It is important to consider the different variables that can influence a floor system's performance. In order to ensure the performance of your floor system, follow the installation guide's recommendations and guidelines. The following considerations can make a difference and will help ensure the satisfaction of the building owner.

## TRUSS DEPTH

For a given chord size, the greater the truss depth, the better the performance. In a typical project, an increase in the depth of the Posi-Strut floor from 9.25" to 11.875", will result in a minimal increase in cost (only a few cents per linear foot) while substantially increasing the floor performance.

## TYPE OF WOOD USED

When consulting the load tables in the following pages, it is important to note that Posi-Strut trusses can be manufactured using different sizes and grades of wood, ensuring performance while also allowing for material optimization. Posi-Strut trusses are fabricated exclusively with wood having a moisture content of 19% or less. The lumber is visually graded and/or MSR (Machine Stress-Rated).

## TRUSS SPACING

The spacing between floor trusses is a variable that should always be carefully considered. A narrower spacing will allow for the use of a thinner subfloor. However, for floor trusses spaced at 19.2" o.c. or 24" o.c., the selection of the type, quality and thickness of subfloor will require additional consideration. Please refer to the National Building Code, the subfloor manufacturer's literature or your local building authority for further details.

## DEFLECTION CRITERIA

The National Building Code limits live load deflection to L/360. With longer spans than conventional sawn lumber, this criterion might seem liberal, considering the span ranges of engineered floor products. Although L/360 meets the minimum code requirement, the building's designer should consider the maximum allowable deflection and floor performance to determine acceptability. Using an L/480 deflection limit will be more restrictive and may be preferable for certain projects.

## QUALITY AND THICKNESS OF THE SUBFLOORING

The quality of the subflooring is something that should not be neglected. This element acts as a bridge between the various structural elements. Choosing a thicker, quality subfloor will contribute to your overall satisfaction with your floor system's performance.

## NAILING

Nailing of the joist might seem trivial but it can definitely affect the floor's performance. Always use nails as specified, both in terms of length and diameter. Floor performance can also be affected if the bearing connections are not detailed correctly.

## USE OF CONSTRUCTION ADHESIVE FOR THE SUBFLOORING AND DIFFERENT ASSEMBLIES

One of the most popular myths in the construction industry concerns floor noise. In reality, joists do not squeak; it is the components within the assemblies that are the source of the problem. In most cases, problems are caused by friction or slight movement of a nail against the wood fibre of a component, or gaps between elements that allows for movement. Fortunately, the use of construction adhesive has become more mainstream in the industry and floor systems are better for it. Use of a high-quality adhesive product is recommended. Urethane based products do not shrink upon hardening. They are also resistant to humidity, do not require perfectly smooth surfaces and do not emit COVs when drying (as they are not solvent based).

It is also important to fasten the subflooring to the trusses immediately following the application of the construction adhesive. Waiting until the adhesive is dry to screw down the subfloor is a common mistake, one that can cause floor systems to squeak. Temporarily attaching a subfloor with a few nails, only to install screws a few days later, only contributes to the future possibility of floor noises.

## STRONGBACKS

Posi-Strut floors utilize strongback bridging, which enables the trusses to be interconnected and form a system. In most situations, two rows of strongbacks, installed perpendicular to the Posi-Strut trusses, will be required. This bridging will act as a secondary beam element, ensuring better load-sharing between the primary structural elements. Contrary to other systems whose structural components work individually, the Posi-Strut engineered system provides stiffness distribution over several trusses, increasing the overall performance of the floor. Proper installation and positioning (as specified by the manufacturer) are important. All installed strongbacks must be made from kiln-dry wood (KD). Care must be taken to not damage the strongbacks.

In the rare case where a strongback needs to be cut or notched, please contact your manufacturer to obtain an alternative field detail. It is important to use specified nails and / or screws and that there is good contact between the strongback and the chord/post to which it is attached. Poor nailing contact can cause future squeaking/noise problems. The addition of construction adhesive between components will help to substantially prevent squeaks.

## INSTALLATION OF A GYPSUM CEILING DIRECTLY UNDER POSI-STRUTS

Although the primary use for gypsum is for finishing the building, it has other important roles. In fact, according to the National Building Code's criteria for reduced vibration, gypsum contributes to a better performance of the floor system. When installed directly below the bottom chord, the gypsum's mass effect positively contributes to the dynamic performance of the floor system. Gypsum also serves as a protective layer for combustible structural elements. Although the National Building Code does not require the installation of gypsum on basement ceilings of residences, we recommend it as it is an economical way to protect the structural components. For additional information, please refer to the certified fire and sound assemblies found on pages 24 to 35 of this document.

## Residential Floor L/360 - Live Load Deflection Nailed & Glued Subfloor No Ceiling applied

DESIGN CRITERIA		TC LL:	40 PSF
This truss is designed for the floor requirements of <b>Part 4, NBCC 2010/2015</b> .  This design complies with: <b>CSA 086-09 /14</b> <b>CCMC: 12691-R</b>		TC DL:	10 PSF
		BC LL:	0 PSF
		BC DL:	5 PSF
		Total:	55 PSF
		LL Defl. Bare Joist:	L/360
		LL Defl. System:	L/360
TL Defl.:	L/180		

PS-10V2	SIZE ▶	3x2 SPF				4x2 SPF			
	GRADE ▼	12" o.c.	16" o.c.	19.2" o.c.	24" o.c.	12" o.c.	16" o.c.	19.2" o.c.	24" o.c.
Depth	SPF no. 2	16'-4"	14'-4"	12'-11"	11'-6"	18'-3"	16'-6"	15'-5"	13'-8"
9 1/4"	SPF MSR 1650f-1.5E	16'-9"	15'-1"	14'-3"	13'-0"	18'-9"	16'-11"	15'-9"	14'-7"
	SPF MSR 2100f-1.8E	17'-10"	16'-1"	15'-1"	13'-11"	19'-1"	17'-11"	16'-10"	15'-5"
	SPF MSR 2400f-2.0E	18'-5"	16'-8"	15'-7"	14'-5"	19'-1"	18'-7"	17'-5"	16'-0"

PS-12	SIZE ▶	3x2 SPF				4x2 SPF			
	GRADE ▼	12" o.c.	16" o.c.	19.2" o.c.	24" o.c.	12" o.c.	16" o.c.	19.2" o.c.	24" o.c.
Depth	SPF no. 2	18'-8"	16'-0"	14'-9"	12'-11"	21'-2"	18'-9"	17'-5"	15'-6"
11 1/4"	SPF MSR 1650f-1.5E	19'-8"	17'-9"	16'-8"	14'-11"	21'-7"	19'-10"	18'-8"	17'-2"
	SPF MSR 2100f-1.8E	20'-7"	18'-11"	17'-9"	16'-3"	22'-8"	21'-1"	19'-9"	17'-10"
	SPF MSR 2400f-2.0E	21'-4"	19'-7"	18'-5"	16'-11"	22'-10"	21'-8"	20'-3"	18'-0"

PS-12i	SIZE ▶	3x2 SPF				4x2 SPF			
	GRADE ▼	12" o.c.	16" o.c.	19.2" o.c.	24" o.c.	12" o.c.	16" o.c.	19.2" o.c.	24" o.c.
Depth	SPF no. 2	19'-3"	16'-6"	15'-3"	13'-5"	21'-10"	19'-9"	17'-11"	15'-11"
11 7/8"	SPF MSR 1650f-1.5E	20'-5"	18'-6"	17'-4"	15'-6"	22'-3"	20'-8"	19'-4"	17'-6"
	SPF MSR 2100f-1.8E	21'-5"	19'-7"	18'-5"	16'-11"	23'-5"	21'-8"	20'-6"	17'-6"
	SPF MSR 2400f-2.0E	22'-0"	20'-4"	19'-0"	17'-6"	23'-9"	22'-3"	20'-11"	17'-6"

PS-13	SIZE ▶	3x2 SPF				4x2 SPF			
	GRADE ▼	12" o.c.	16" o.c.	19.2" o.c.	24" o.c.	12" o.c.	16" o.c.	19.2" o.c.	24" o.c.
Depth	SPF no. 2	20'-1"	16'-8"	15'-10"	14'-0"	22'-9"	20'-7"	18'-7"	16'-9"
12 3/4"	SPF MSR 1650f-1.5E	20'-10"	19'-5"	18'-4"	16'-7"	23'-3"	21'-8"	20'-5"	18'-10"
	SPF MSR 2100f-1.8E	22'-5"	20'-8"	19'-5"	17'-10"	24'-5"	22'-8"	21'-7"	19'-2"
	SPF MSR 2400f-2.0E	22'-11"	20'-10"	20'-1"	18'-0"	25'-1"	23'-5"	22'-0"	19'-2"

PS-14V3	SIZE ▶	3x2 SPF				4x2 SPF			
	GRADE ▼	12" o.c.	16" o.c.	19.2" o.c.	24" o.c.	12" o.c.	16" o.c.	19.2" o.c.	24" o.c.
Depth	SPF no. 2	21'-2"	17'-7"	16'-8"	14'-9"	24'-0"	21'-6"	19'-8"	17'-8"
14"	SPF MSR 1650f-1.5E	21'-11"	20'-4"	19'-1"	17'-3"	24'-7"	22'-7"	21'-3"	18'-11"
	SPF MSR 2100f-1.8E	23'-8"	21'-7"	20'-3"	18'-7"	25'-9"	23'-8"	22'-7"	18'-11"
	SPF MSR 2400f-2.0E	24'-4"	22'-4"	20'-11"	18'-9"	26'-6"	24'-7"	23'-0"	18'-11"

PS-16V3	SIZE ▶	3x2 SPF				4x2 SPF			
	GRADE ▼	12" o.c.	16" o.c.	19.2" o.c.	24" o.c.	12" o.c.	16" o.c.	19.2" o.c.	24" o.c.
Depth	SPF no. 2	22'-2"	19'-8"	17'-5"	16'-0"	26'-0"	22'-10"	21'-5"	18'-8"
16"	SPF MSR 1650f-1.5E	24'-5"	22'-3"	20'-5"	18'-6"	26'-6"	24'-8"	23'-1"	18'-11"
	SPF MSR 2100f-1.8E	25'-7"	23'-9"	22'-5"	18'-10"	27'-10"	25'-10"	23'-1"	18'-11"
	SPF MSR 2400f-2.0E	26'-3"	24'-6"	23'-1"	18'-10"	28'-7"	26'-7"	23'-1"	18'-11"

### GENERAL NOTES

- Spans shown are overall spans and include 1.5" bearing on each end of the Posi truss. Spans are in units of feet and inches.
- Some spans require specific webbing configurations [such as double webbing]. These tables cannot be used on their own for fabrication of the Posi-Strut system. Consult MiTek engineering drawings for final webbing configuration of each Posi-Strut design.
- Minimum bearing size as indicated on the Posi-Strut design drawings but must be at least 1.5 inches.
- Provide restraints at supports to ensure lateral stability. The Posi-strut system requires lateral restraints on top and bottom edges.
- Vibration has been checked using SPF No. 2 strongbacks (2x6 for spans < 24 ft. and 2x8 for all others). Posi-Strut floor spacing of 12" o.c. may require heavier strongback configurations.
- Alternate strongback sizes than those indicated in note [5] may also be acceptable. Consult with the Posi-Strut floor supplier for alternate strongback configurations.
- See individual Posi-Strut design drawings for strongback sizes and locations.
- Subfloor sheathing must possess the span rating for the anticipated spacing of the Posi-Strut floor (minimum 5/8" subfloor thickness).
- Design assumes dry lumber at time of fabrication [moisture content < 19%].

### STRESS INCREASES:

DOL Lumber = 1.00  
 Nail = 1.00  
 Bending = 1.10  
 Compression = 1.10  
 Shear = 1.10  
 Tension = 1.10



# Residential Floor

## L/360 - Live Load Deflection

### Nailed & Glued Subfloor

### 1x3 Strapping + Gypsum 1/2"

DESIGN CRITERIA		TC LL:	40 PSF
This truss is designed for the floor requirements of <b>Part 4, NBCC 2010/2015</b> .  This design complies with: <b>CSA 086-09 /14</b> <b>CCMC: 12691-R</b>		TC DL:	10 PSF
		BC LL:	0 PSF
		BC DL:	5 PSF
		Total:	55 PSF
		LL Defl. Bare Joist:	L/360
		LL Defl. System:	L/360
	TL Defl.:	L/180	

PS-10V2	SIZE ▶	3x2 SPF				4x2 SPF			
	GRADE ▼	12" o.c.	16" o.c.	19.2" o.c.	24" o.c.	12" o.c.	16" o.c.	19.2" o.c.	24" o.c.
Depth	SPF no. 2	16'-4"	14'-4"	12'-11"	11'-6"	18'-3"	16'-6"	15'-5"	13'-8"
9 1/4"	SPF MSR 1650f-1.5E	16'-9"	15'-1"	14'-3"	13'-0"	18'-9"	16'-11"	15'-9"	14'-7"
	SPF MSR 2100f-1.8E	17'-10"	16'-1"	15'-1"	13'-11"	19'-1"	17'-11"	16'-10"	15'-5"
	SPF MSR 2400f-2.0E	18'-5"	16'-8"	15'-7"	14'-5"	19'-1"	18'-7"	17'-5"	16'-0"

PS-12	SIZE ▶	3x2 SPF				4x2 SPF			
	GRADE ▼	12" o.c.	16" o.c.	19.2" o.c.	24" o.c.	12" o.c.	16" o.c.	19.2" o.c.	24" o.c.
Depth	SPF no. 2	18'-8"	16'-0"	14'-9"	12'-11"	21'-4"	18'-9"	17'-5"	15'-6"
11 1/4"	SPF MSR 1650f-1.5E	19'-8"	17'-9"	16'-8"	14'-11"	21'-11"	19'-10"	18'-8"	17'-2"
	SPF MSR 2100f-1.8E	20'-11"	18'-11"	17'-9"	16'-3"	23'-1"	21'-1"	19'-9"	17'-10"
	SPF MSR 2400f-2.0E	21'-8"	19'-7"	18'-5"	16'-11"	23'-1"	21'-10"	20'-5"	18'-0"

PS-12i	SIZE ▶	3x2 SPF				4x2 SPF			
	GRADE ▼	12" o.c.	16" o.c.	19.2" o.c.	24" o.c.	12" o.c.	16" o.c.	19.2" o.c.	24" o.c.
Depth	SPF no. 2	19'-3"	16'-6"	15'-3"	13'-5"	22'-3"	19'-9"	17'-11"	15'-11"
11 7/8"	SPF MSR 1650f-1.5E	20'-5"	18'-6"	17'-4"	15'-6"	22'-10"	20'-8"	19'-4"	17'-6"
	SPF MSR 2100f-1.8E	21'-9"	19'-8"	18'-5"	16'-11"	24'-0"	22'-0"	20'-6"	17'-6"
	SPF MSR 2400f-2.0E	22'-5"	20'-4"	19'-0"	17'-6"	24'-3"	22'-8"	21'-2"	17'-6"

PS-13	SIZE ▶	3x2 SPF				4x2 SPF			
	GRADE ▼	12" o.c.	16" o.c.	19.2" o.c.	24" o.c.	12" o.c.	16" o.c.	19.2" o.c.	24" o.c.
Depth	SPF no. 2	20'-1"	16'-8"	15'-10"	14'-0"	23'-5"	20'-7"	18'-7"	16'-9"
12 3/4"	SPF MSR 1650f-1.5E	21'-7"	19'-5"	18'-4"	16'-7"	23'-11"	21'-10"	20'-5"	18'-10"
	SPF MSR 2100f-1.8E	22'-11"	20'-9"	19'-5"	17'-10"	25'-0"	23'-1"	21'-8"	19'-2"
	SPF MSR 2400f-2.0E	23'-7"	21'-6"	20'-1"	18'-0"	25'-8"	23'-11"	22'-4"	19'-2"

PS-14V3	SIZE ▶	3x2 SPF				4x2 SPF			
	GRADE ▼	12" o.c.	16" o.c.	19.2" o.c.	24" o.c.	12" o.c.	16" o.c.	19.2" o.c.	24" o.c.
Depth	SPF no. 2	21'-2"	17'-7"	16'-8"	14'-9"	24'-6"	21'-6"	19'-8"	17'-8"
14"	SPF MSR 1650f-1.5E	22'-5"	20'-4"	19'-1"	17'-3"	25'-2"	22'-8"	21'-3"	18'-11"
	SPF MSR 2100f-1.8E	23'-11"	21'-7"	20'-3"	18'-7"	26'-4"	24'-1"	22'-7"	18'-11"
	SPF MSR 2400f-2.0E	24'-9"	22'-4"	20'-11"	18'-9"	27'-1"	24'-11"	23'-0"	18'-11"

PS-16V3	SIZE ▶	3x2 SPF				4x2 SPF			
	GRADE ▼	12" o.c.	16" o.c.	19.2" o.c.	24" o.c.	12" o.c.	16" o.c.	19.2" o.c.	24" o.c.
Depth	SPF no. 2	22'-2"	19'-8"	17'-5"	16'-0"	26'-9"	22'-10"	21'-5"	18'-8"
16"	SPF MSR 1650f-1.5E	24'-11"	22'-3"	20'-5"	18'-6"	27'-3"	25'-1"	23'-1"	18'-11"
	SPF MSR 2100f-1.8E	26'-4"	23'-11"	22'-5"	18'-10"	28'-6"	26'-5"	23'-1"	18'-11"
	SPF MSR 2400f-2.0E	27'-0"	24'-9"	23'-1"	18'-10"	29'-3"	27'-2"	23'-1"	18'-11"

**GENERAL NOTES**

- Spans shown are overall spans and include 1.5" bearing on each end of the Posi truss. Spans are in units of feet and inches.
- Some spans require specific webbing configurations (such as double webbing). These tables cannot be used on their own for fabrication of the Posi-Strut system. Consult MiTek engineering drawings for final webbing configuration of each Posi-Strut design.
- Minimum bearing size as indicated on the Posi-Strut design drawings but must be at least 1.5 inches.
- Provide restraints at supports to ensure lateral stability. The Posi-strut system requires lateral restraints on top and bottom edges.
- Vibration has been checked using SPF No. 2 strongbacks (2x6 for spans < 24 ft. and 2x8 for all others). Posi-Strut floor spacing of 12" o.c. may require heavier strongback configurations.
- Alternate strongback sizes than those indicated in note [5] may also be acceptable. Consult with the Posi-Strut floor supplier for alternate strongback configurations.
- See individual Posi-Strut design drawings for strongback sizes and locations.
- Subfloor sheathing must possess the span rating for the anticipated spacing of the Posi-Strut floor (minimum 5/8" subfloor thickness).
- Design assumes dry lumber at time of fabrication (moisture content < 19%).

**STRESS INCREASES:**

DOL Lumber = 1.00  
 Nail = 1.00  
 Bending = 1.10  
 Compression = 1.10  
 Shear = 1.10  
 Tension = 1.10

## Residential Floor L/480 - Live Load Deflection Nailed & Glued Subfloor No Ceiling applied

DESIGN CRITERIA		TC LL:	40 PSF
This truss is designed for the floor requirements of <b>Part 4, NBCC 2010/2015</b> .  This design complies with: <b>CSA 086-09 /14</b> <b>CCMC: 12691-R</b>		TC DL:	10 PSF
		BC LL:	0 PSF
		BC DL:	5 PSF
		Total:	55 PSF
		LL Defl. Bare Joist:	L/360
		LL Defl. System:	L/480
TL Defl.:	L/240		

PS-10V2	SIZE ▶	3x2 SPF				4x2 SPF			
	GRADE ▼	12" o.c.	16" o.c.	19.2" o.c.	24" o.c.	12" o.c.	16" o.c.	19.2" o.c.	24" o.c.
Depth	SPF no. 2	15'-3"	14'-0"	12'-11"	11'-6"	17'-0"	15'-5"	14'-6"	13'-6"
9 1/4"	SPF MSR 1650f-1.5E	15'-8"	14'-4"	13'-6"	12'-6"	17'-5"	15'-10"	14'-10"	13'-10"
	SPF MSR 2100f-1.8E	16'-6"	15'-0"	14'-2"	13'-3"	18'-5"	16'-9"	15'-8"	14'-7"
	SPF MSR 2400f-2.0E	17'-2"	15'-8"	14'-8"	13'-7"	19'-1"	17'-3"	16'-2"	15'-0"

PS-12	SIZE ▶	3x2 SPF				4x2 SPF			
	GRADE ▼	12" o.c.	16" o.c.	19.2" o.c.	24" o.c.	12" o.c.	16" o.c.	19.2" o.c.	24" o.c.
Depth	SPF no. 2	17'-10"	16'-0"	14'-9"	12'-11"	19'-10"	18'-1"	17'-1"	15'-6"
11 1/4"	SPF MSR 1650f-1.5E	18'-4"	16'-9"	15'-10"	14'-9"	20'-4"	18'-6"	17'-6"	16'-2"
	SPF MSR 2100f-1.8E	19'-3"	17'-7"	16'-7"	15'-6"	21'-6"	19'-7"	18'-6"	17'-1"
	SPF MSR 2400f-2.0E	20'-1"	18'-3"	17'-3"	15'-11"	22'-4"	20'-4"	19'-1"	17'-7"

PS-12i	SIZE ▶	3x2 SPF				4x2 SPF			
	GRADE ▼	12" o.c.	16" o.c.	19.2" o.c.	24" o.c.	12" o.c.	16" o.c.	19.2" o.c.	24" o.c.
Depth	SPF no. 2	18'-6"	16'-6"	15'-3"	13'-5"	20'-8"	18'-10"	17'-9"	15'-11"
11 7/8"	SPF MSR 1650f-1.5E	19'-1"	17'-5"	16'-5"	15'-4"	21'-2"	19'-3"	18'-2"	16'-9"
	SPF MSR 2100f-1.8E	20'-0"	18'-3"	17'-2"	16'-1"	22'-5"	20'-5"	19'-1"	17'-6"
	SPF MSR 2400f-2.0E	20'-10"	19'-0"	17'-11"	16'-7"	23'-2"	21'-1"	19'-9"	17'-6"

PS-13	SIZE ▶	3x2 SPF				4x2 SPF			
	GRADE ▼	12" o.c.	16" o.c.	19.2" o.c.	24" o.c.	12" o.c.	16" o.c.	19.2" o.c.	24" o.c.
Depth	SPF no. 2	19'-7"	16'-8"	15'-10"	14'-0"	21'-9"	19'-10"	18'-7"	16'-9"
12 3/4"	SPF MSR 1650f-1.5E	20'-1"	18'-4"	17'-4"	16'-1"	22'-4"	20'-4"	19'-2"	17'-8"
	SPF MSR 2100f-1.8E	21'-1"	19'-3"	18'-1"	16'-11"	23'-7"	21'-6"	20'-2"	18'-8"
	SPF MSR 2400f-2.0E	22'-0"	20'-0"	18'-11"	17'-6"	24'-5"	22'-2"	20'-9"	19'-2"

PS-14V3	SIZE ▶	3x2 SPF				4x2 SPF			
	GRADE ▼	12" o.c.	16" o.c.	19.2" o.c.	24" o.c.	12" o.c.	16" o.c.	19.2" o.c.	24" o.c.
Depth	SPF no. 2	20'-5"	17'-7"	16'-8"	14'-9"	22'-9"	20'-7"	19'-5"	17'-8"
14"	SPF MSR 1650f-1.5E	21'-0"	19'-1"	17'-11"	16'-7"	23'-3"	21'-1"	19'-10"	18'-5"
	SPF MSR 2100f-1.8E	22'-0"	20'-1"	18'-10"	17'-7"	24'-8"	22'-4"	21'-0"	18'-11"
	SPF MSR 2400f-2.0E	22'-11"	20'-10"	19'-7"	18'-2"	25'-6"	23'-0"	21'-8"	18'-11"

PS-16V3	SIZE ▶	3x2 SPF				4x2 SPF			
	GRADE ▼	12" o.c.	16" o.c.	19.2" o.c.	24" o.c.	12" o.c.	16" o.c.	19.2" o.c.	24" o.c.
Depth	SPF no. 2	22'-2"	19'-8"	17'-5"	16'-0"	25'-1"	22'-9"	21'-5"	18'-8"
16"	SPF MSR 1650f-1.5E	23'-2"	21'-2"	19'-11"	18'-6"	25'-9"	23'-2"	21'-11"	18'-11"
	SPF MSR 2100f-1.8E	24'-5"	22'-1"	20'-10"	18'-10"	27'-2"	24'-9"	23'-1"	18'-11"
	SPF MSR 2400f-2.0E	25'-5"	22'-11"	21'-8"	18'-10"	28'-2"	25'-6"	23'-1"	18'-11"

### GENERAL NOTES

- Spans shown are overall spans and include 1.5" bearing on each end of the Posi truss. Spans are in units of feet and inches.
- Some spans require specific webbing configurations [such as double webbing]. These tables cannot be used on their own for fabrication of the Posi-Strut system. Consult MiTek engineering drawings for final webbing configuration of each Posi-Strut design.
- Minimum bearing size as indicated on the Posi-Strut design drawings but must be at least 1.5 inches.
- Provide restraints at supports to ensure lateral stability. The Posi-strut system requires lateral restraints on top and bottom edges.
- Vibration has been checked using SPF No. 2 strongbacks (2x6 for spans < 24 ft. and 2x8 for all others). Posi-Strut floor spacing of 12" o.c. may require heavier strongback configurations.
- Alternate strongback sizes than those indicated in note [5] may also be acceptable. Consult with the Posi-Strut floor supplier for alternate strongback configurations.
- See individual Posi-Strut design drawings for strongback sizes and locations.
- Subfloor sheathing must possess the span rating for the anticipated spacing of the Posi-Strut floor (minimum 5/8" subfloor thickness).
- Design assumes dry lumber at time of fabrication [moisture content < 19%].

### STRESS INCREASES:

DOL Lumber = 1.00  
 Nail = 1.00  
 Bending = 1.10  
 Compression = 1.10  
 Shear = 1.10  
 Tension = 1.10

**Residential Floor**  
**L/480 - Live Load Deflection**  
**Nailed & Glued Subfloor**  
**1x3 strapping + Gypsum 1/2"**

DESIGN CRITERIA		TC LL:	40 PSF
This truss is designed for the floor requirements of <b>Part 4, NBCC 2010/2015</b> .  This design complies with: <b>CSA 086-09 /14</b> <b>CCMC: 12691-R</b>		TC DL:	10 PSF
		BC LL:	0 PSF
		BC DL:	5 PSF
		Total:	55 PSF
		LL Defl. Bare Joist:	L/360
		LL Defl. System:	L/480
TL Defl.:	L/240		

PS-10V2	SIZE ▶	3x2 SPF				4x2 SPF			
	GRADE ▼	12" o.c.	16" o.c.	19.2" o.c.	24" o.c.	12" o.c.	16" o.c.	19.2" o.c.	24" o.c.
Depth	SPF no. 2	15'-6"	14'-3"	13'-2"	11'-9"	17'-3"	15'-8"	14'-9"	13'-9"
9 1/4"	SPF MSR 1650f-1.5E	15'-11"	14'-7"	13'-9"	12'-9"	17'-8"	16'-1"	15'-1"	14'-1"
	SPF MSR 2100f-1.8E	16'-9"	15'-3"	14'-5"	13'-6"	18'-8"	17'-0"	15'-11"	14'-10"
	SPF MSR 2400f-2.0E	17'-5"	15'-11"	14'-11"	13'-10"	19'-4"	17'-6"	16'-5"	15'-3"

PS-12	SIZE ▶	3x2 SPF				4x2 SPF			
	GRADE ▼	12" o.c.	16" o.c.	19.2" o.c.	24" o.c.	12" o.c.	16" o.c.	19.2" o.c.	24" o.c.
Depth	SPF no. 2	18'-1"	16'-3"	15'-0"	13'-2"	20'-1"	18'-4"	17'-4"	15'-9"
11 1/4"	SPF MSR 1650f-1.5E	18'-7"	17'-0"	16'-1"	15'-0"	20'-7"	18'-9"	17'-9"	16'-5"
	SPF MSR 2100f-1.8E	19'-6"	17'-10"	16'-10"	15'-9"	21'-9"	19'-10"	18'-9"	17'-4"
	SPF MSR 2400f-2.0E	20'-4"	18'-6"	17'-6"	16'-2"	22'-7"	20'-7"	19'-4"	17'-10"

PS-12i	SIZE ▶	3x2 SPF				4x2 SPF			
	GRADE ▼	12" o.c.	16" o.c.	19.2" o.c.	24" o.c.	12" o.c.	16" o.c.	19.2" o.c.	24" o.c.
Depth	SPF no. 2	18'-9"	16'-9"	15'-6"	13'-8"	20'-11"	19'-1"	18'-0"	16'-2"
11 7/8"	SPF MSR 1650f-1.5E	19'-4"	17'-8"	16'-8"	15'-7"	21'-5"	19'-6"	18'-5"	17'-0"
	SPF MSR 2100f-1.8E	20'-3"	18'-6"	17'-5"	16'-4"	22'-8"	20'-8"	19'-4"	17'-9"
	SPF MSR 2400f-2.0E	21'-1"	19'-3"	18'-2"	16'-10"	23'-5"	21'-4"	20'-0"	17'-9"

PS-13	SIZE ▶	3x2 SPF				4x2 SPF			
	GRADE ▼	12" o.c.	16" o.c.	19.2" o.c.	24" o.c.	12" o.c.	16" o.c.	19.2" o.c.	24" o.c.
Depth	SPF no. 2	19'-10"	16'-11"	16'-1"	14'-3"	22'-0"	20'-1"	18'-10"	17'-0"
12 3/4"	SPF MSR 1650f-1.5E	20'-4"	18'-7"	17'-7"	16'-4"	22'-7"	20'-7"	19'-5"	17'-11"
	SPF MSR 2100f-1.8E	21'-4"	19'-6"	18'-4"	17'-2"	23'-10"	21'-9"	20'-5"	18'-11"
	SPF MSR 2400f-2.0E	22'-3"	20'-3"	19'-2"	17'-9"	24'-8"	22'-5"	21'-0"	19'-5"

PS-14V3	SIZE ▶	3x2 SPF				4x2 SPF			
	GRADE ▼	12" o.c.	16" o.c.	19.2" o.c.	24" o.c.	12" o.c.	16" o.c.	19.2" o.c.	24" o.c.
Depth	SPF no. 2	20'-8"	17'-10"	16'-11"	15'-0"	23'-0"	20'-10"	19'-8"	17'-11"
14"	SPF MSR 1650f-1.5E	21'-3"	19'-4"	18'-2"	16'-10"	23'-6"	21'-4"	20'-1"	18'-8"
	SPF MSR 2100f-1.8E	22'-3"	20'-4"	19'-1"	17'-10"	24'-11"	22'-7"	21'-3"	19'-2"
	SPF MSR 2400f-2.0E	23'-2"	21'-1"	19'-10"	18'-5"	25'-9"	23'-3"	21'-11"	19'-2"

PS-16V3	SIZE ▶	3x2 SPF				4x2 SPF			
	GRADE ▼	12" o.c.	16" o.c.	19.2" o.c.	24" o.c.	12" o.c.	16" o.c.	19.2" o.c.	24" o.c.
Depth	SPF no. 2	22'-5"	19'-11"	17'-8"	16'-3"	25'-4"	23'-0"	21'-8"	18'-11"
16"	SPF MSR 1650f-1.5E	23'-5"	21'-5"	20'-2"	18'-9"	26'-0"	23'-5"	22'-2"	19'-2"
	SPF MSR 2100f-1.8E	24'-8"	22'-4"	21'-1"	19'-1"	27'-5"	25'-0"	23'-4"	19'-2"
	SPF MSR 2400f-2.0E	25'-8"	23'-2"	21'-11"	19'-1"	28'-5"	25'-9"	23'-4"	19'-2"

**GENERAL NOTES**

- Spans shown are overall spans and include 1.5" bearing on each end of the Posi truss. Spans are in units of feet and inches.
- Some spans require specific webbing configurations (such as double webbing). These tables cannot be used on their own for fabrication of the Posi-Strut system. Consult MiTek engineering drawings for final webbing configuration of each Posi-Strut design.
- Minimum bearing size as indicated on the Posi-Strut design drawings but must be at least 1.5 inches.
- Provide restraints at supports to ensure lateral stability. The Posi-strut system requires lateral restraints on top and bottom edges.
- Vibration has been checked using SPF No. 2 strongbacks (2x6 for spans < 24 ft. and 2x8 for all others). Posi-Strut floor spacing of 12" o.c. may require heavier strongback configurations.
- Alternate strongback sizes than those indicated in note [5] may also be acceptable. Consult with the Posi-Strut floor supplier for alternate strongback configurations.
- See individual Posi-Strut design drawings for strongback sizes and locations.
- Subfloor sheathing must possess the span rating for the anticipated spacing of the Posi-Strut floor (minimum 5/8" subfloor thickness).
- Design assumes dry lumber at time of fabrication (moisture content < 19%).

**STRESS INCREASES:**

DOL Lumber = 1.00  
 Nail = 1.00  
 Bending = 1.10  
 Compression = 1.10  
 Shear = 1.10  
 Tension = 1.10

Proper coordination and open communication between all subcontractors are essential during the design and installation stages. Too often, structural elements are cut, notched or damaged as a result of lack of planning. Performance of the structural element is affected and, in some cases, damage is irreparable and replacement is extremely expensive. Better planning between the different subcontractors saves time and money while ensuring the structural integrity of the building. Please review the installation layout, important dimensions and instructions before starting the installation of the Posi-Strut system. The following points should be reviewed, planned and discussed at the design stage. For any questions you may have, please contact your Posi-Strut manufacturer.

## SUBFLOOR

To prevent cracks in heavy floor tiles (ceramic, porcelain, slate, etc.), it is important to choose the appropriate type, quality and thickness of subfloor. A minimum of 1.0" (subfloor and backer board combination) is required to ensure proper support to the finished flooring material. In addition, the backer board must be installed perpendicular to the subfloor and the joints must be overlapped to avoid any dimensional variance.

## ELECTRICITY

Although electric wires are less intrusive due to their smaller size, the fact remains that the vertical passage of wiring may encounter obstructions caused by the structural elements. Again, pre-design planning will avoid headaches or costly repairs on the job site. Particular attention should be taken when an interior wall is parallel to a floor joist or beam.

## PLUMBING

One of the most common cases of damage to structural floor components is the passage of vertical plumbing through the chord of the structural element. Yet, simply planning ahead allows the contractor and subcontractor to properly position the floor joists. In doing so, the subcontractor can easily position the vertical mechanical obstructions (ex. toilet, drain within the walls, vents, etc.) without having to cut or damage the structural elements. Posi-Strut manufacturers pay particular attention to this issue and often structural elements are adapted to the situation and adjustments are clearly indicated on the installation plan. Unfortunately, this valuable information is rarely considered by carpenters and last-minute changes are not brought to the attention of the Posi-Strut manufacturer. If you need to move a Posi-Strut truss on-site, please consult your authorized Posi-Strut manufacturer first.

### Vertical plumbing installation

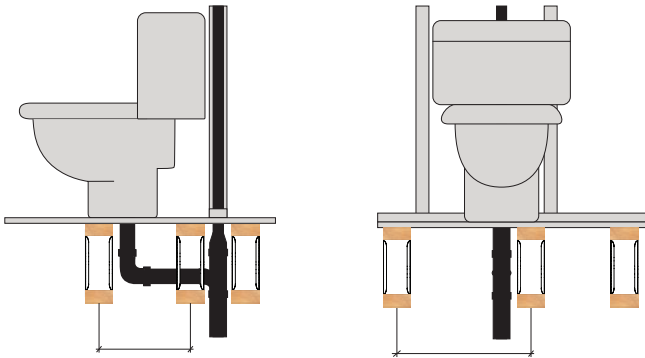

**When planning the installation and faced with potential problems with plumbing, electricity or ductwork interfering with the truss, please contact your Posi-Strut manufacturer.**

They will check if one of the Posi-Struts can be slightly moved to avoid damaging the truss. If this is not possible, the addition of another Posi-Strut may be necessary. Although this option will be slightly more expensive, it will provide better support and minimize the potential of finished flooring cracking caused by poor support and deformation of the subfloor.

## VENTILATION DUCTS

To avoid unpleasant surprises on the job site, it is important to inform your Posi-Strut manufacturer of the positioning and the dimensions of the different ventilation ducts for your project. They can then better advise you on available options, and design the floor according to your specifications. Good planning will allow, when possible, the passage of large ducts through the Posi-Strut truss floor cavity.

## HANDLING

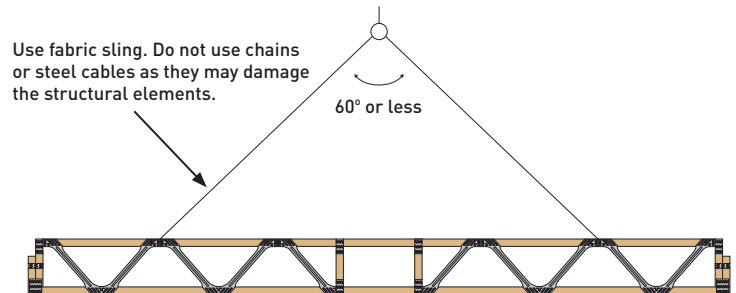
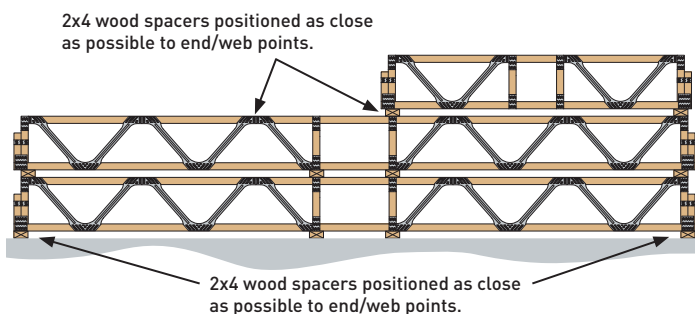

**DO NOT OVERLOAD FLOOR WITH BUILDING MATERIALS. MAKE SURE TO DISTRIBUTE THE LOADS UNIFORMLY ON THE FLOOR SO AS TO NOT EXCEED THE DESIGN LOADS. DO NOT CUT, DRILL INTO, OR ALTER THE POSI-STRUT COMPONENTS, NOR CUT NOTCHES IN THE STRONGBACKS. PLEASE REFER TO MITEK POSI-STRUT INSTALLATION GUIDE FOR FURTHER DETAILS.**

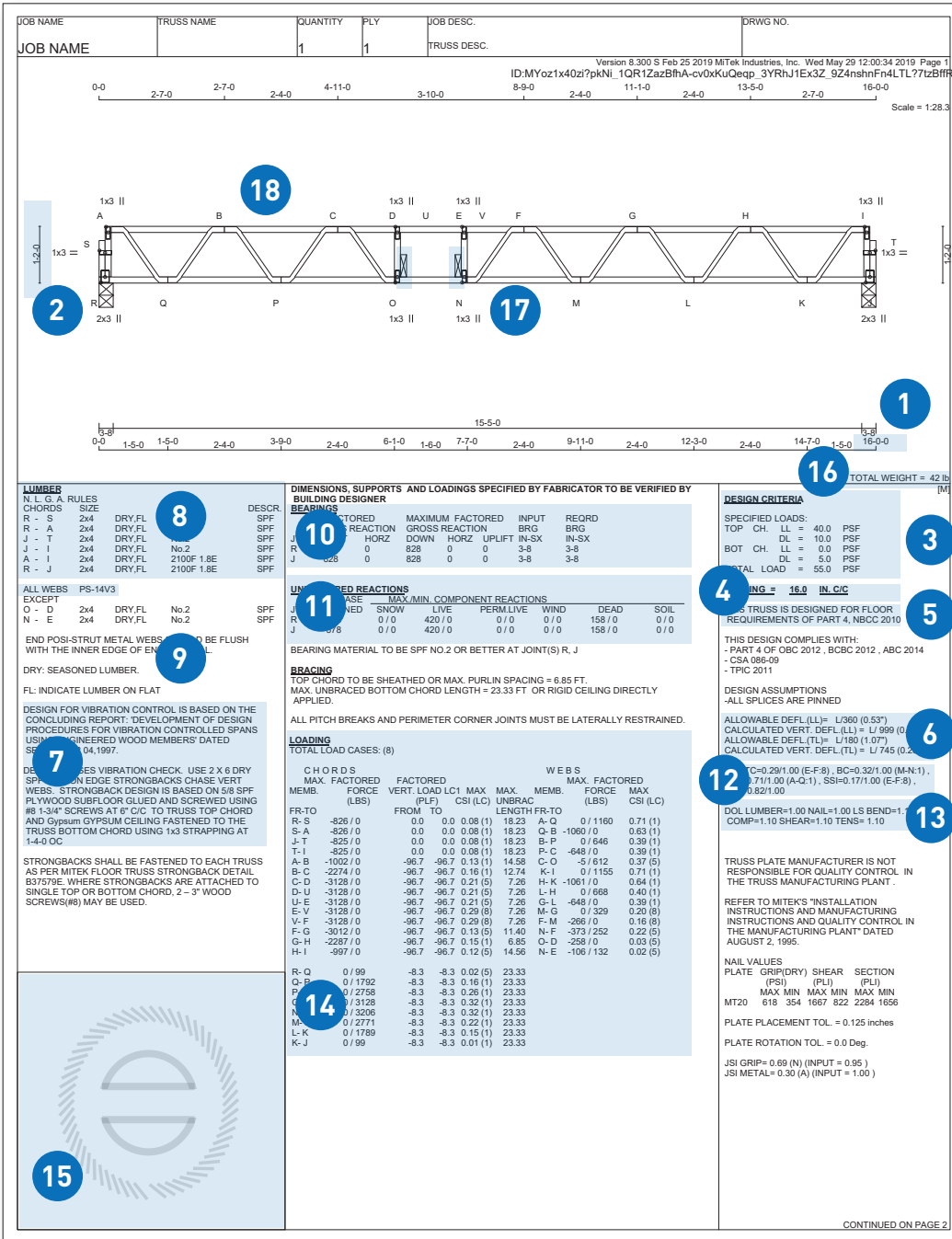

HOW TO READ A MITEK ENGINEERING DRAWING

Your regional Posi-Strut manufacturer will provide a copy of all engineering drawings as well as a detailed installation plan and any additional details that the carpenter / builder will require during construction.

To understand the specific parameters used to design the different Posi-Strut elements that compose the floor system, a detailed legend of important drawing information is provided here for reference.

The project engineer can easily review Posi-Strut drawings to ensure that the designs meet or exceed the project requirements.

- 1 Overall span expressed in Feet-Inches-Sixteenths (FT-IN-SX).
- 2 Posi-Strut depth expressed in Feet-Inches-Sixteenths (FT-IN-SX).
- 3 Unfactored design loads in pounds per square feet for the top chord, bottom chord and the total load. LL defines the Live Loads and DL the Dead loads.
- 4 Posi-Strut on centre spacing expressed in decimal inches.
- 5 Applicable design codes and standards.
- 6 Allowable and calculated vertical deflection under the Live Load (LL) and Total Load (TL) calculation. The number in brackets represents the allowable or the calculated measure in decimal inches.
- 7 Vibration control information as well as the exact floor composition materials that were used in the design of the Posi-Strut.
- 8 Top and bottom chord description. This includes the lumber sizes, moisture content, orientation, species, grades and certification agency.
- 9 Web / vertical post description. This includes the lumber sizes, moisture content, orientation, species and grades.
- 10 Bearing locations, input and required sizes, factored vertical, horizontal and uplift reactions.
- 11 Unfactored reactions [Combined on load case 1, Snow, Live, Permanent-Live, Wind, Dead and Soil] used in the design.
- 12 Combined Stress Index (CSI) expressed in decimal for the Top Chord (TC), Bottom Chord (BC), Webs (WB). Vr represents the ratio for the vibration control limitation.
- 13 Duration of Load for plate and lumber design and Repetitive Use Factor.
- 14 Detailed factored member forces Tension (+), Compression (-)
- 15 Seal of the Professional Engineer that reviewed and approved the drawing.
- 16 Posi-Strut estimated weight.
- 17 Graphical representation of the Strongback positioning
- 18 Graphical representation of the Posi-Strut configuration.

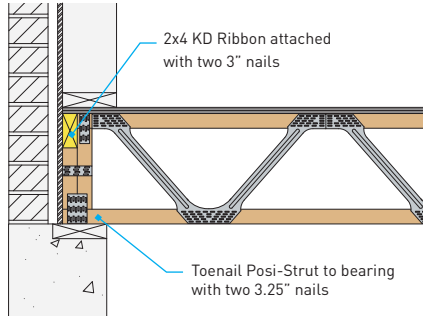
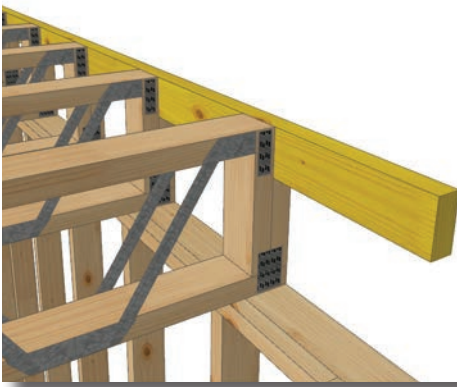

**BRICK WALL WITH SINGLE 2x4 RIBBON** PS1

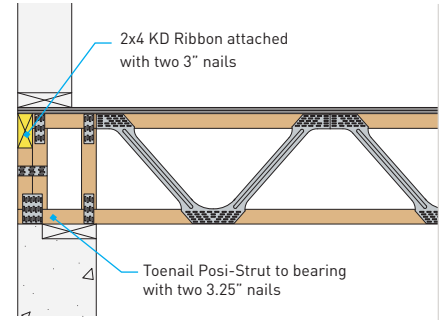

**WIDE BEARING WITH SINGLE 2x4 RIBBON** PS2

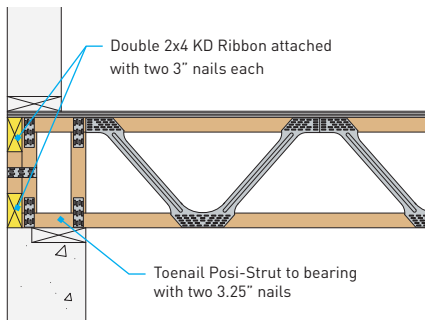

**WIDE BEARING WITH DOUBLE 2x4 RIBBON** PS3

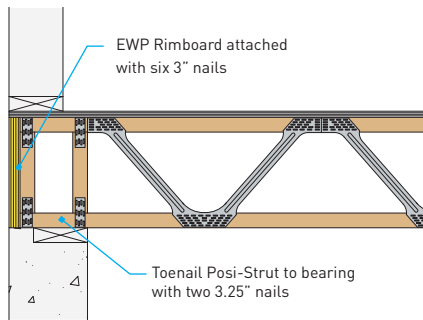

**WIDE BEARING WITH RIMBOARD** PS4

*Since Posi-Strut is custom-built for your project, the vertical load transfer details are planned in advance for your building*

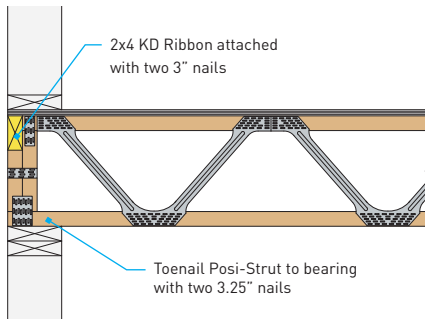

**WOOD WALL BEARING WITH SINGLE 2x4 RIBBON** PS7

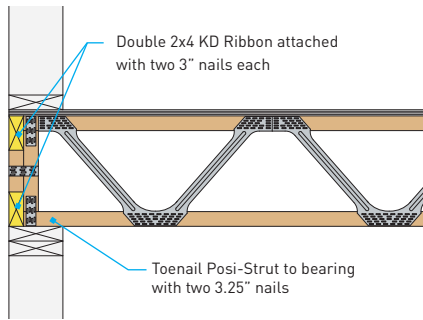

**WOOD WALL BEARING WITH DOUBLE 2x4 RIBBON** PS8

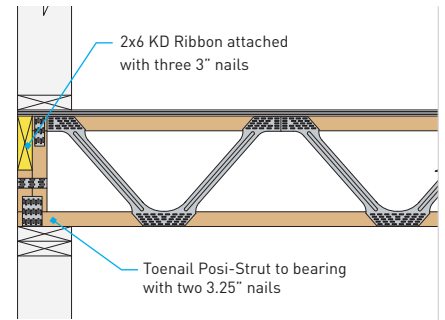

**WOOD WALL BEARING WITH SINGLE 2x6 RIBBON** PS9

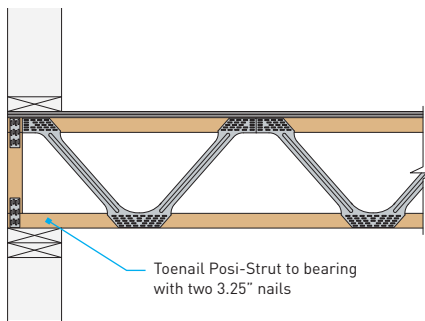

**WOOD WALL BEARING WITH SINGLE POST** PS5

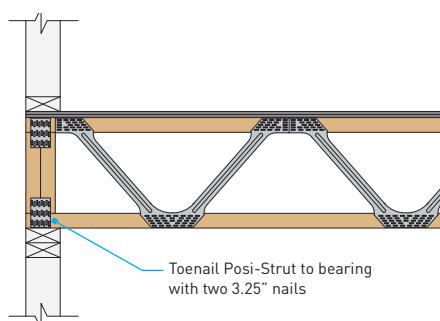

**WOOD WALL BEARING WITH DOUBLE POST** PS6

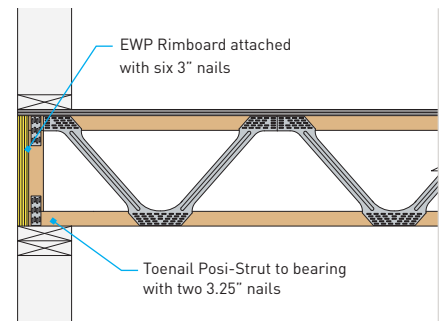

**WOOD WALL BEARING WITH SINGLE POST AND RIMBOARD** PS11

NOTE: Untreated lumber should not have direct contact with concrete.

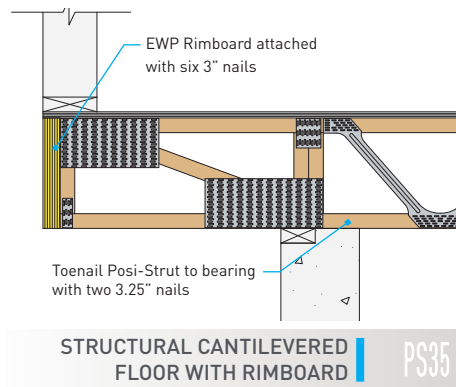
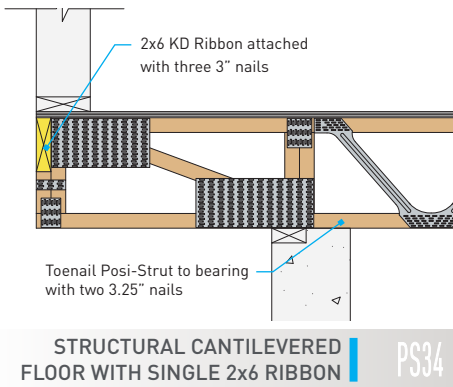
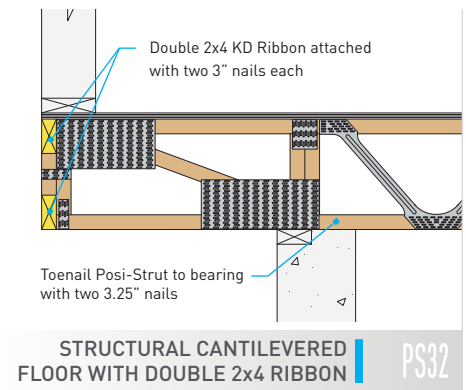
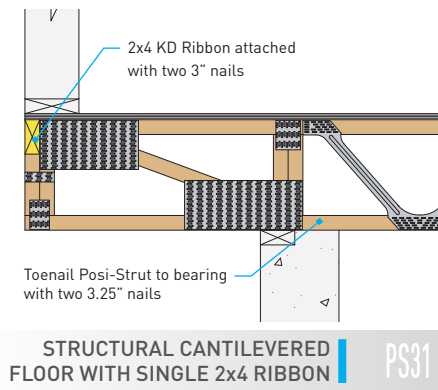
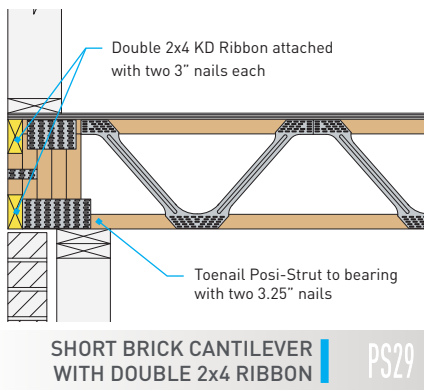
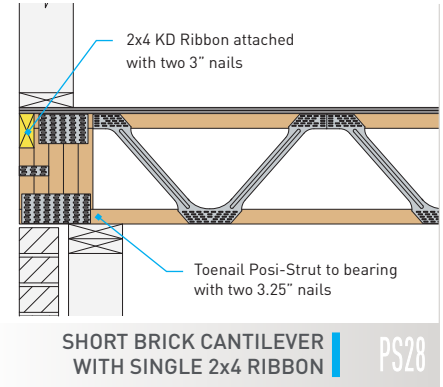
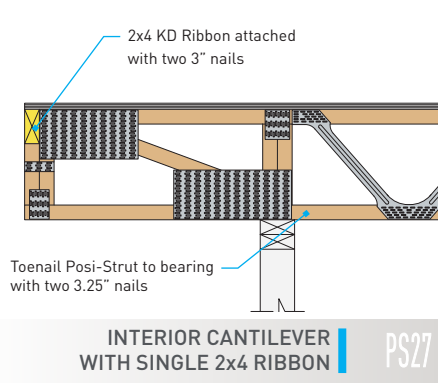
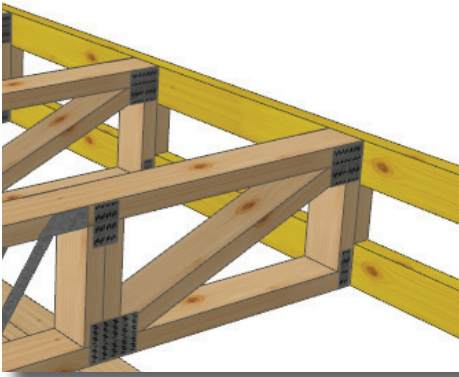

*Special custom details  
can be designed to avoid  
costly reinforcement  
details on-site.*

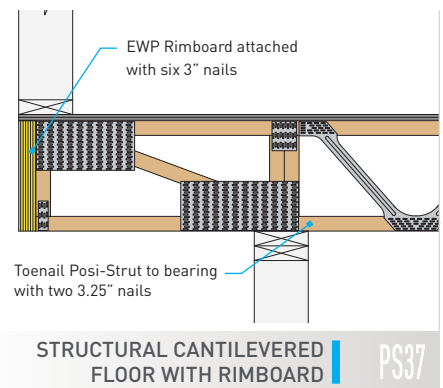
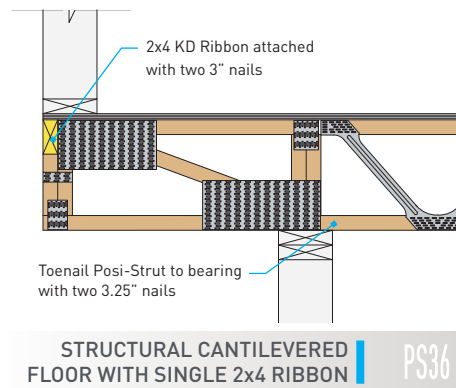
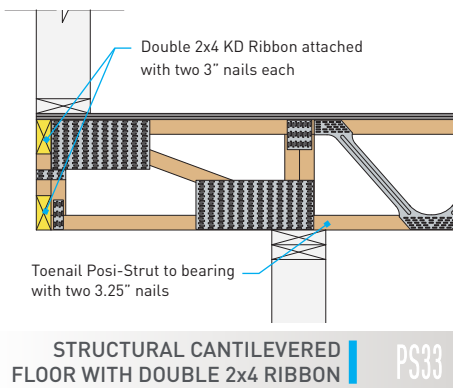

NOTE: Untreated lumber should not have direct contact with concrete.

# Top Chord Bearing Details

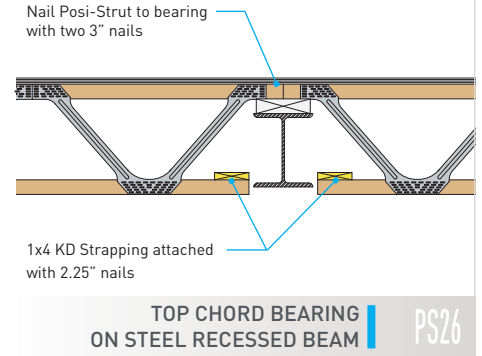
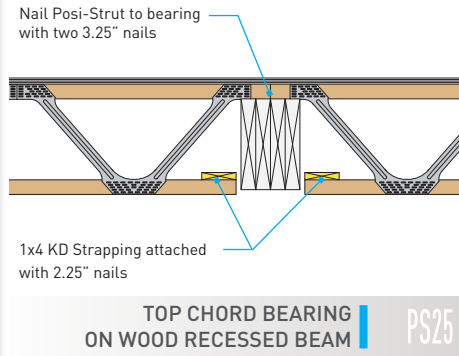
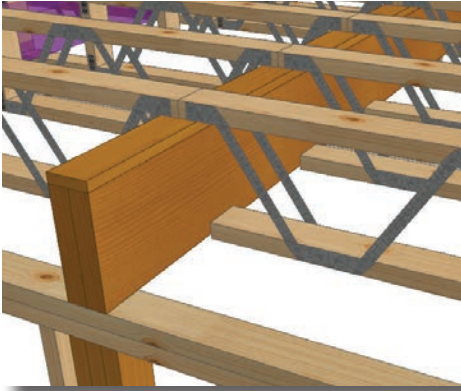

## Note concerning top chord bearing installation

In many applications, Posi-Strut does not require the use of hangers. In the top chord bearing condition (with no end vertical detail), the first diagonals must overlap the bearing by 1 inch to ensure proper load transfer. Install 1x4 strapping at 7 feet o.c. as per code if no ceiling is applied against the bottom chord of the Posi-Strut.

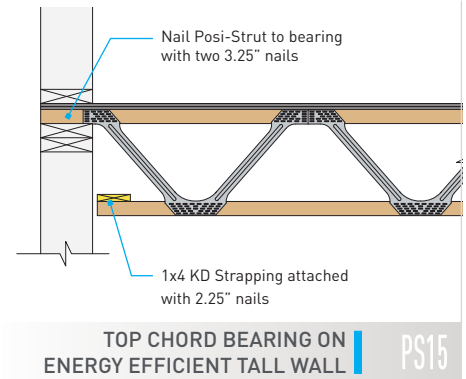
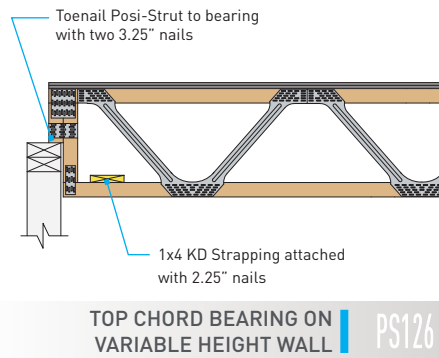
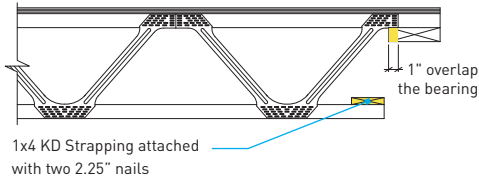

# Adjustable End Details

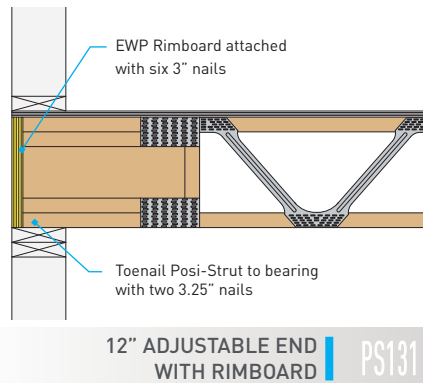
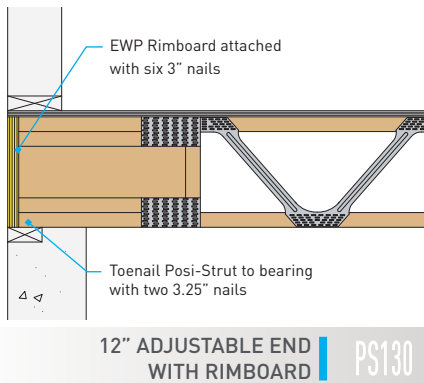
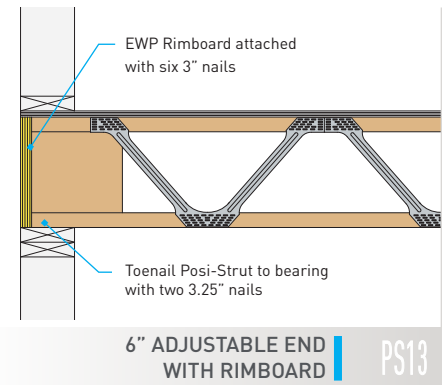
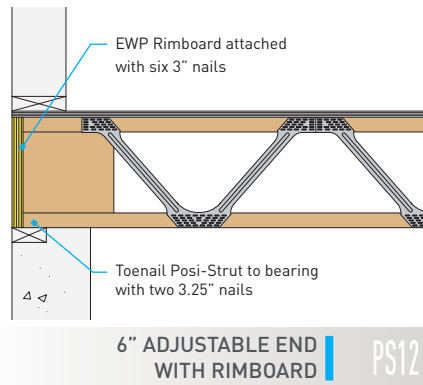
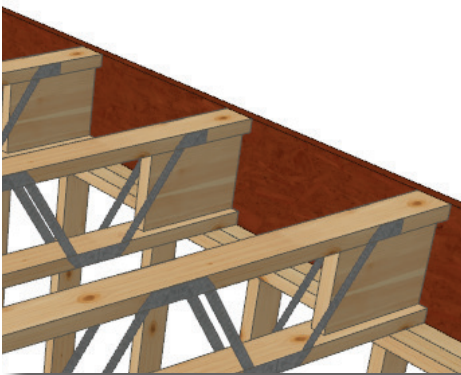

- **Design flexibility**
- **Reduced material costs**
- **Saves labour on-site**
- **Energy efficient**



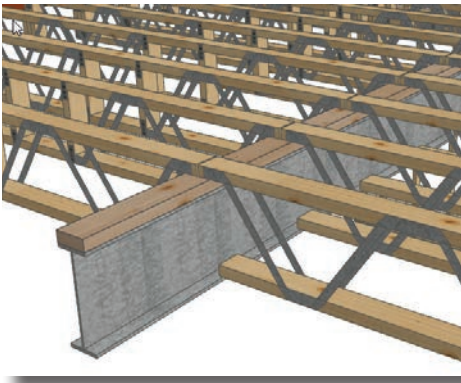

Nail Posi-Strut to bearing with two 3.25" nails

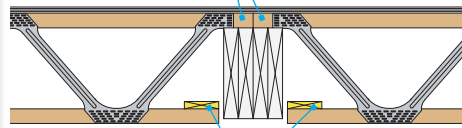

1x4 KD Strapping attached with 2.25" nails

**TOP CHORD BEARING ON WOOD RECESSED BEAM** | PS25

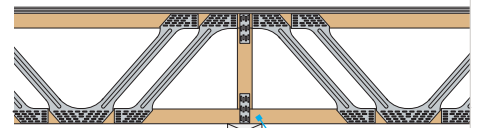

Toenail Posi-Strut to bearing with two 3.25" nails

**CONTINUOUS SPAN WITH SINGLE POST** | PS21

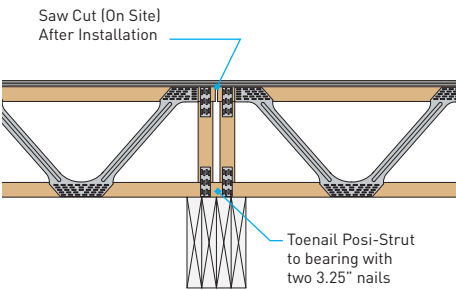

**CONTINUOUS SPAN WITH TOP CHORD SAW CUT DETAIL** | PS22

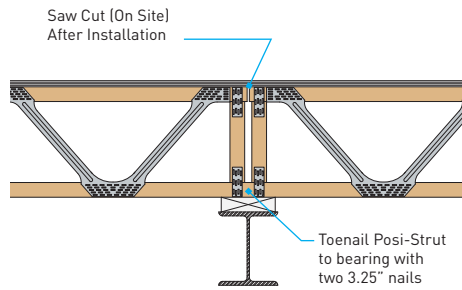

**CONTINUOUS SPAN WITH TOP CHORD SAW CUT DETAIL** | PS23

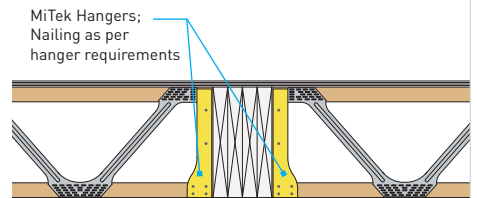

**WOOD RECESSED BEAM WITH HANGER CONNECTION** | PS24

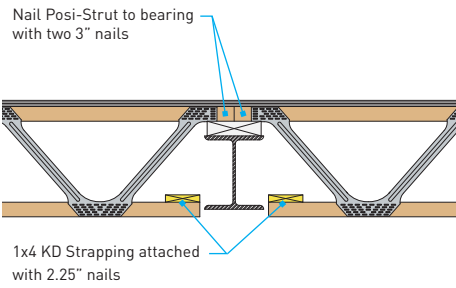

**TOP CHORD BEARING ON STEEL RECESSED BEAM** | PS26

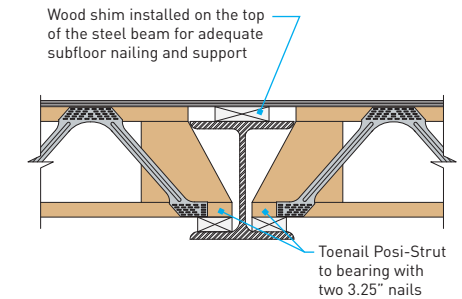

**FIRE CUT DETAIL ON STEEL BEAM** | PS14

*The Engineered Floor System  
that allows a multitude of  
**POSI-BILITIES***

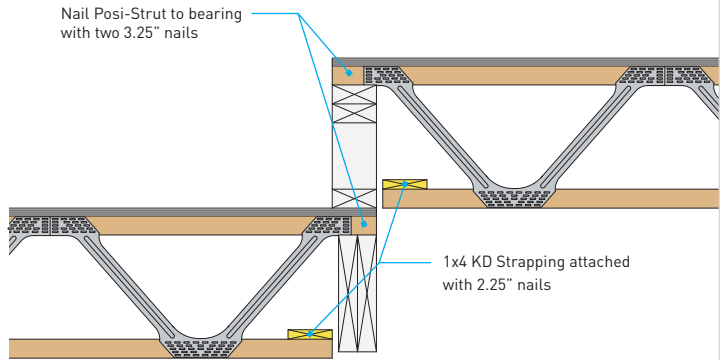
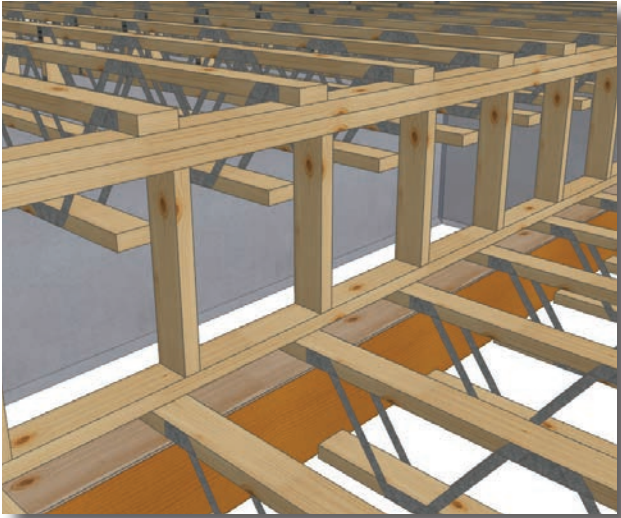

**TOP CHORD / TOP CHORD BEARING ASSEMBLY** PS16

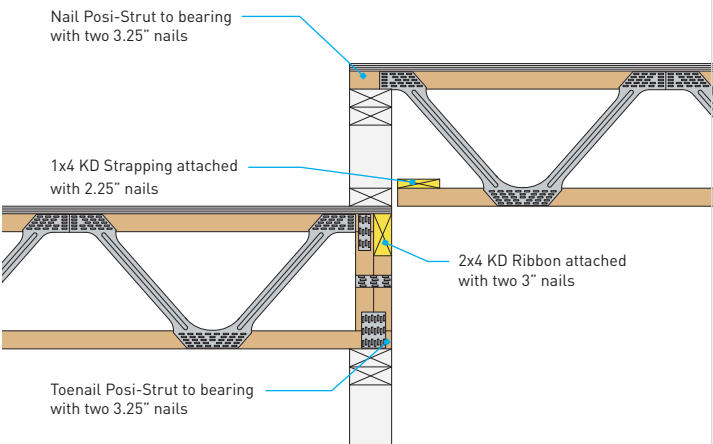

**BOTTOM CHORD / TOP CHORD BEARING ASSEMBLY** PS19

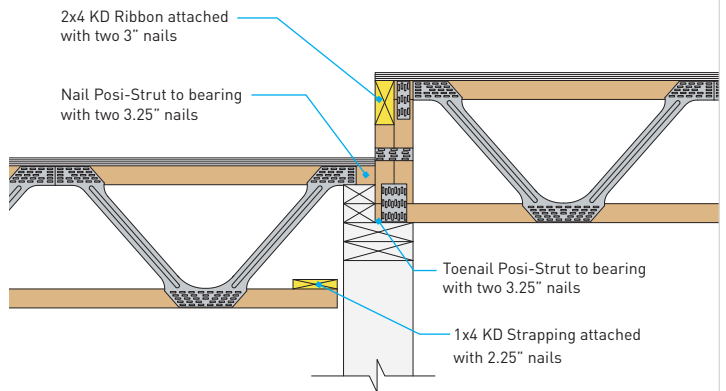

**TOP CHORD / BOTTOM CHORD BEARING ASSEMBLY** PS18

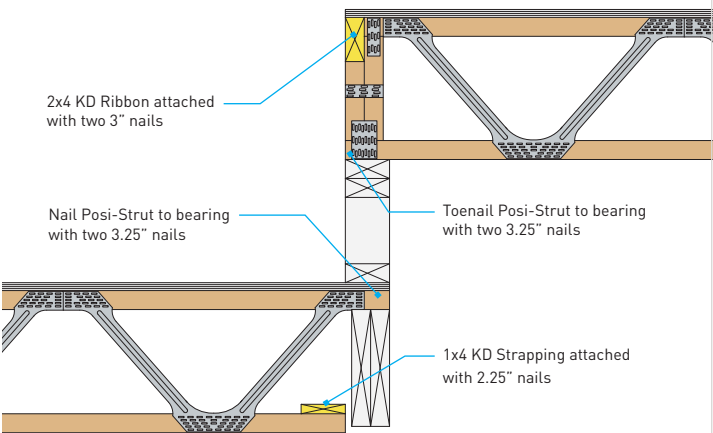

**TOP CHORD / BOTTOM CHORD BEARING ASSEMBLY** PS17

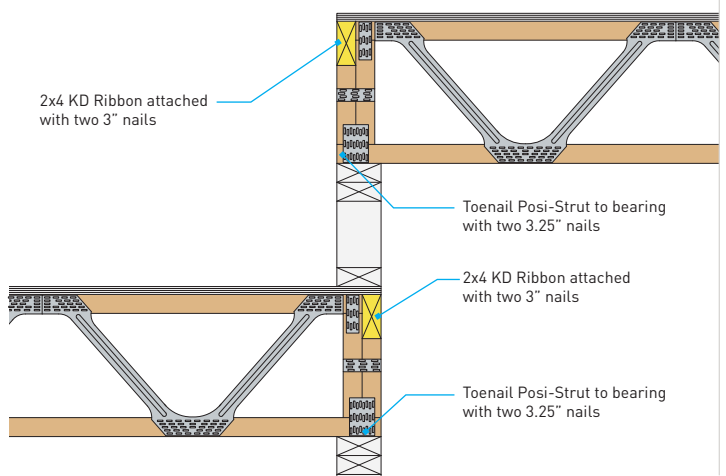

**BOTTOM CHORD / BOTTOM CHORD BEARING ASSEMBLY** PS20

## MAXIMUM FLOOR TRUSS FACTORED BEARING CAPACITY (LB) AND FACTORED WALL LOAD (LB) ABOVE TRUSS (FOR LUMBER ON FLAT)

Depending on the different site conditions, Posi-Strut can be produced with additional vertical posts to accommodate vertical load transfer from above. The table below indicates the maximum factored load capacities for various common conditions. Please inform your Posi-Strut manufacturer of any special project requirements.

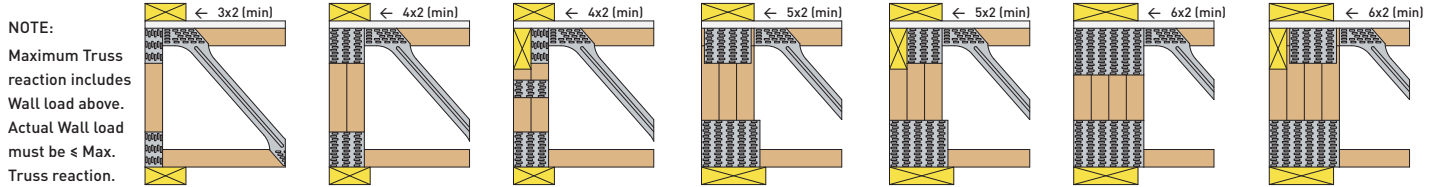

Max. Wall load:	2537 lb (on top of truss)		5074 lb (on top of truss)		4201 lb (on top of truss)		7611 lb (on top of truss)		6738 lb (on top of truss)		9725 lb (on top of truss)		9275 lb (on top of truss)		
	Max. Truss Reaction, lb		Max. Truss Reaction, lb		Max. Truss Reaction, lb		Max. Truss Reaction, lb		Max. Truss Reaction, lb		Max. Truss Reaction, lb		Max. Truss Reaction, lb		
	Bearing width, in	SPF # 2	MSR 2100 <sup>2</sup>	SPF # 2	MSR 2100 <sup>2</sup>	SPF # 2	MSR 2100 <sup>2</sup>	SPF # 2	MSR 2100 <sup>2</sup>	SPF # 2	MSR 2100 <sup>2</sup>	SPF # 2	MSR 2100 <sup>2</sup>	SPF # 2	MSR 2100 <sup>2</sup>
3 x 2 chord	1.5	2306	2306	2306	2306	2306	2306	2306	2306	2306	2306	2306	2306	2306	2306
	1.75	2537	2691	2691	2691	2691	2691	2691	2691	2691	2691	2691	2691	2691	2691
	2.5	2537	3111	4228	4228	4228	4228	4228	4228	4228	4228	4228	4228	4228	4228
	2.625	2537	3111	4490	4490	4490	4490	4490	4490	4490	4490	4490	4490	4490	4490
	2.75	2537	3111	4757	4757	4757	4757	4757	4757	4757	4757	4757	4757	4757	4757
	3	2537	3111	4613	4613	4613	4613	4613	4613	4613	4613	4613	4613	4613	4613
	3.5	2537	3111	5074	6188	4843	5417	6188	6188	6188	6188	6188	6188	6188	6188
	4	2537	3111	5074	6222	4843	5417	7073	7073	7073	7073	7073	7073	7073	7073
	4.5	2537	3111	5074	6222	4843	5417	7611	7957	7380	7957	7957	7957	7957	7957
	5.25	2537	3111	5074	6222	4843	5417	7611	8072	7380	8072	8072	8072	8072	8072
5.5	2537	3111	5074	6222	4843	5417	7611	9333	7380	8528	9725	9725	9725	9725	
6	2537	3111	5074	6222	4843	5417	7611	9333	7380	8528	10148	10609	9917	10609	
4 x 2 chord	1.5	3229	3229	3229	3229	3229	3229	3229	3229	3229	3229	3229	3229	3229	3229
	1.75	3713	3767	3767	3767	3767	3767	3767	3767	3767	3767	3767	3767	3767	3767
	2.5	3713	4553	5919	5919	5919	5919	5919	5919	5919	5919	5919	5919	5919	5919
	2.625	3713	4553	6286	6286	6286	6286	6286	6286	6286	6286	6286	6286	6286	6286
	2.75	3713	4553	6659	6659	6659	6659	6659	6659	6659	6659	6659	6659	6659	6659
	3	3713	4553	6458	6458	6458	6458	6458	6458	6458	6458	6458	6458	6458	6458
	3.5	3713	4553	7426	8664	6942	7782	8664	8664	8664	8664	8664	8664	8664	8664
	4	3713	4553	7426	9107	6942	7782	9902	9902	9902	9902	9902	9902	9902	9902
	4.5	3713	4553	7426	9107	6942	7782	11139	11139	10655	11139	11139	11139	11139	11139
	5.25	3713	4553	7426	9107	6942	7782	11139	11301	10655	11301	11301	11301	11301	11301
5.5	3713	4553	7426	9107	6942	7782	11139	13615	10655	12336	13615	13615	13615	13615	
6	3713	4553	7426	9107	6942	7782	11139	13660	10655	12336	14852	14852	14368	14852	

1. Plate width must cover the greater of bearing width or all vertical posts. Plate must be ≤ 1/8" above bearing surface.
2. Table values for MSR 2100 Fb - 1.8E (or better) apply only to the truss chord lumber and not to ribbon block or bearing material.
3. Maximum truss spacing must be less than or equal to 16" o.c.
4. Wall above truss is flush to outside edge of truss and designed by others. Ribbon block is 2x4 SPF No. 2 DRY, or better, and continuous over truss ends.
5. Bearing plate material is SPF No. 2 DRY (or better). Bearing resistance of other support types (by others) must be > bearing plate resistance.

### TYPICAL VERTICAL LOAD TRANSFER

Depending on the different site conditions and load-path requirements, the project engineer may require blocking for vertical load transfer. To the right is a typical example of blocking needed between the joists to transfer loads from a bearing wall above. This detail indicates only one possibility, but highlights the need to have a proper load path designed for your building.

Please consult the project engineer to ensure that load transfer blocking is properly detailed and adequately installed on-site. It is also the responsibility of the project engineer to determine the different shear and bracing details required for the project.

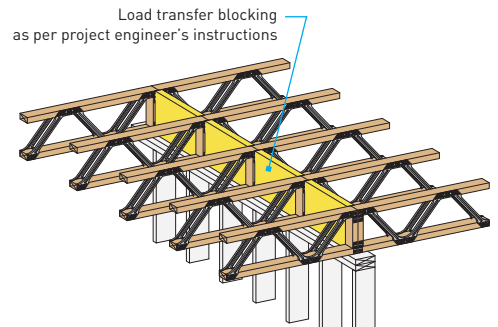

### BLOCKING UNDER NON-LOAD-BEARING WALLS

Installation of 2x4 blocking is required every 24" o.c. to reinforce the subfloor under non-load-bearing partition walls that are parallel to the trusses.

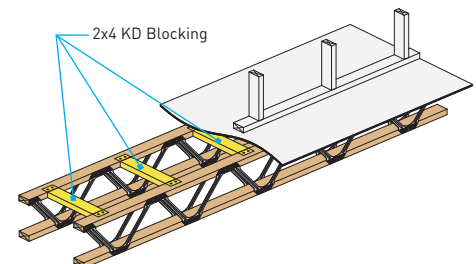

## STAIRCASE ASSEMBLY WITH BEARING WALL

Since the Posi-Strut engineered floor system is custom designed for your project, various staircase details / connections can be produced to meet specific project requirements. The following are the four most commonly used details / connections.

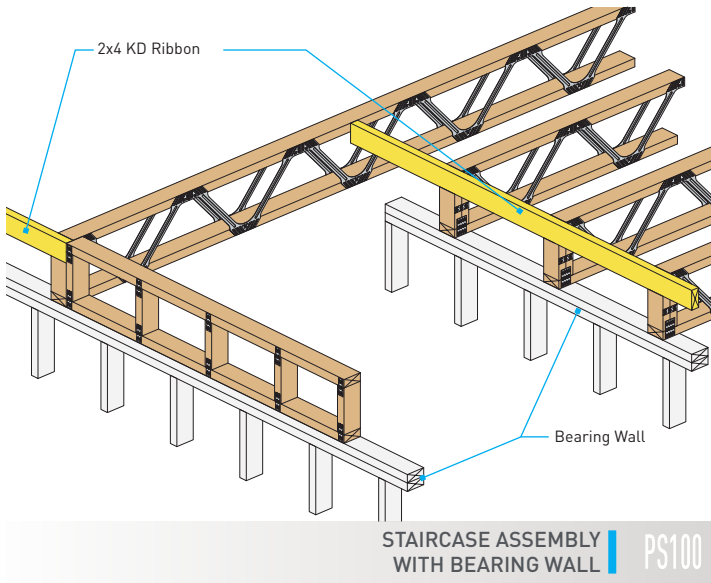

*Posi-Strut can be custom designed to support and frame any staircase configuration*

## STAIRCASE ASSEMBLY WITH STRAP HANGER CONNECTION

Before installing the double Posi-Strut girder in place, install the FTC clips, or MiTek Pro Series screws, as per the tables on page 23. The clips or screws must be carefully positioned to the correct described locations and as close as possible to the concentrated loads. Install the strap hanger and beam.

**Important:** Ensure that the quantity and type of nails used in hanger and FTC connections are as specified by the manufacturer.

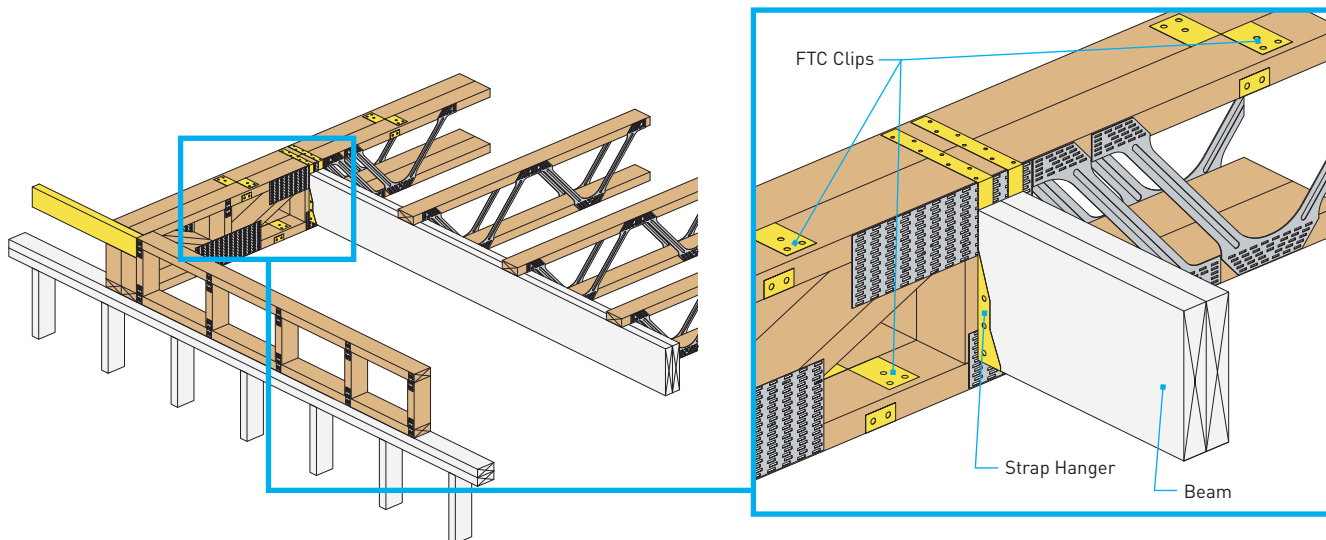

## STAIRCASE ASSEMBLY WITH FACE MOUNT HANGER CONNECTION

Before installing the double Posi-Strut girder in place, install the FTC clips, or MiTek Pro Series screws, as per the tables on page 23. The clips or screws must be carefully positioned to the correct described locations and as close as possible to the concentrated loads. Install the face mount hanger and beam. **Important:** Ensure that the quantity and type of nails used in hanger and FTC connections are as specified by the manufacturer. Ensure hanger nails are installed into solid wood. Should nails fall in between the stacked vertical wood webs or too close to the edge of the web member, verify the adequacy of the connection with the hanger supplier.

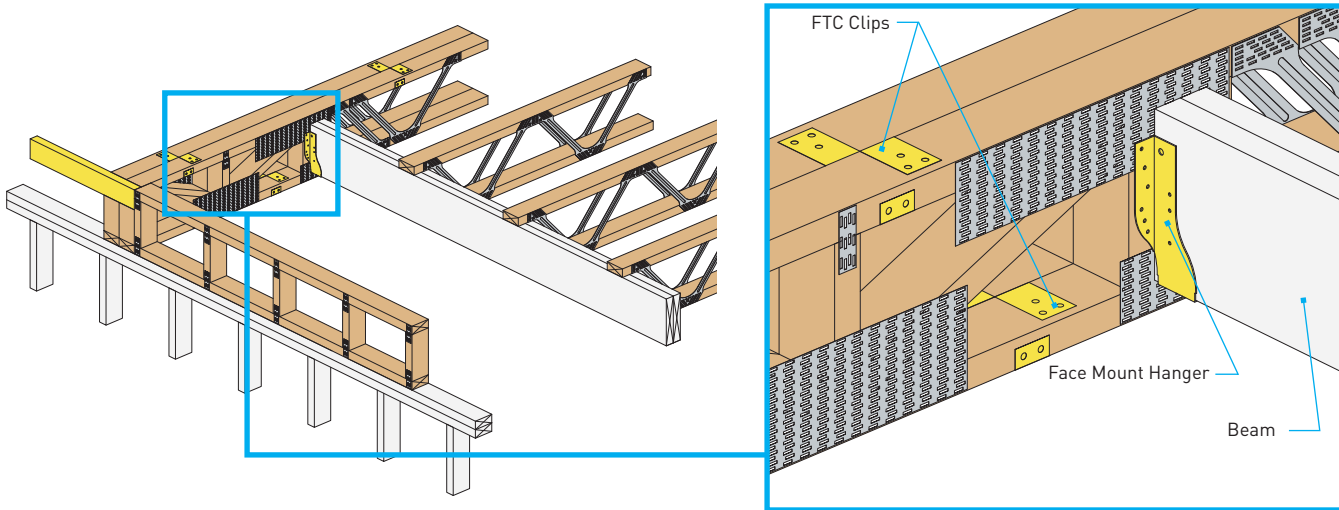

STAIRCASE ASSEMBLY WITH FACE MOUNT HANGER CONNECTION PS103

## STAIRCASE ASSEMBLY WITH BEAM POCKET DETAIL

Before installing the double Posi-Strut girder in place, install the FTC clips, or MiTek Pro Series screws, as per the tables on page 23. The clips or screws must be carefully positioned to the correct described locations and as close as possible to the concentrated loads. Insert the beam in the beam pocket. To fill any gap between the vertical posts and the beam, use strips of plywood. Use nails or MiTek Pro Series screws to ensure good connection between the beam and the Posi-Strut girder.

**Important:** Ensure that the quantity and type of nails used in the FTC connections are as specified by the manufacturer.

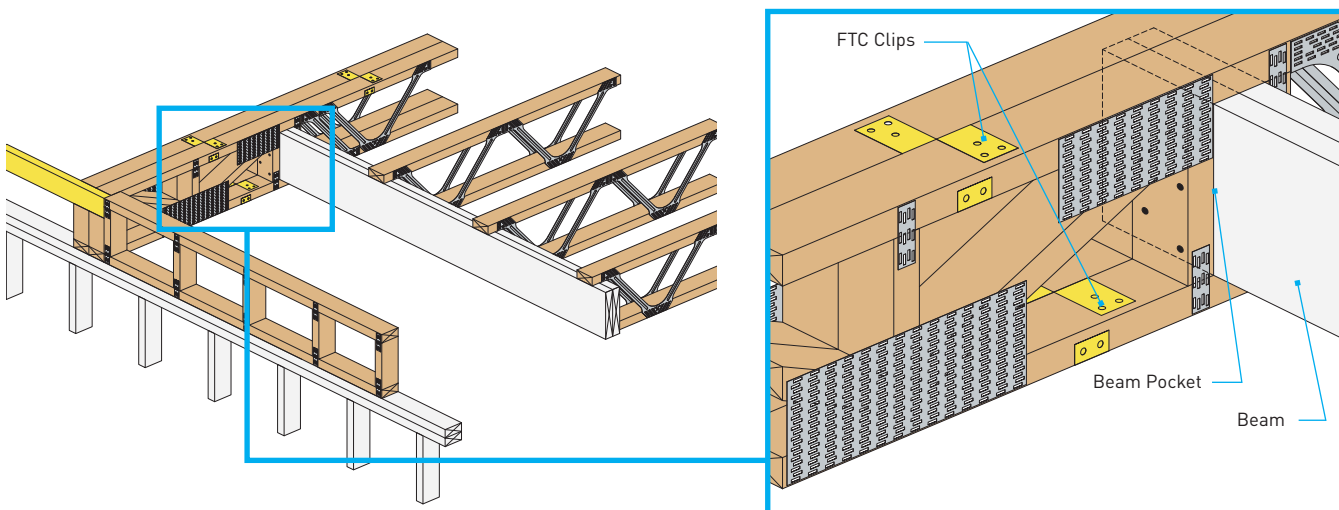

STAIRCASE ASSEMBLY WITH BEAM POCKET DETAIL PS101

Strongbacks are boards of dimensional lumber (usually 2x6) that are positioned at specific locations within the floor system cavity. These boards act as mini beams, introducing a transverse stiffness element that allows the trusses to work together as a **system**, resulting in increased performance of the floor against vibration. Strongback size, grade and positions vary by project and are typically specified on engineering design drawings that are produced by authorized Posi-Strut manufacturers.

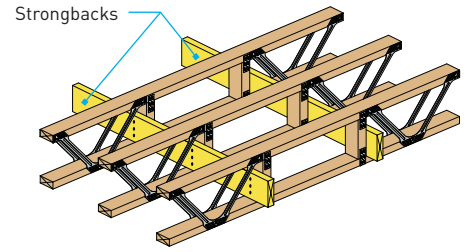

## INSTALLATION AGAINST VERTICAL POSTS

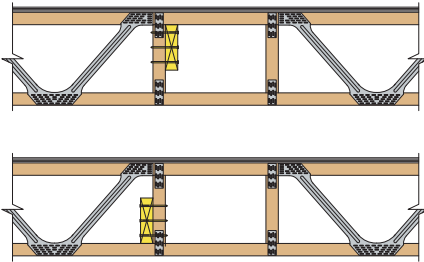

When the strongbacks are positioned against vertical posts, use three 3.25" nails to install the strongbacks.

For a stronger connection, use two 3" #8 screws instead of the nails.

It is important to ensure that the strongback is in perfect contact with the vertical post and the horizontal chord.

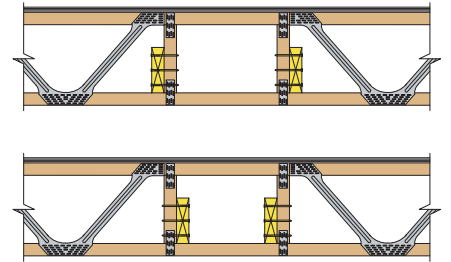

## INSTALLATION AGAINST THE TOP OR BOTTOM CHORD

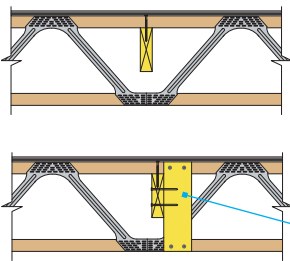

When the strongbacks are positioned against a top or bottom chord, use two 3" #8 screws to install the strongbacks.

It is important to ensure that the strongback is in perfect contact with the top or bottom chord.

When the strongbacks are positioned against the top or bottom chord, the addition of a 2x4 block attached against the top and bottom of the Posi-Strut chords will improve the assembly and performance of the floor system. Connect the strongback and the block with two 3.25" nails or two 3" #8 screws.

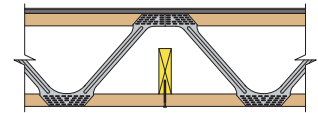

## MITEK ENGINEERING DRAWINGS

A copy of all engineering drawings are sent along with the trusses to the job site and are included with the installation layout and installation guide.

It is essential to consult these documents for specific technical details such as orientation, loading, bearings, spacing and strongback positioning.

Strongback positions (highlighted in yellow) are shown on the Posi-Strut engineering drawings. Position, size, grade and nailing instructions should be respected.

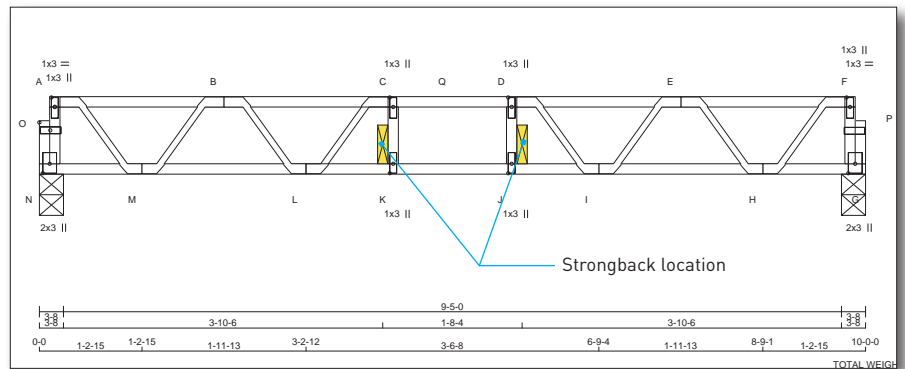

## STRONGBACK SPLICING

The following details can be used to connect different strongback pieces. Both connections ensure a good performance of the strongback.

### Scab option

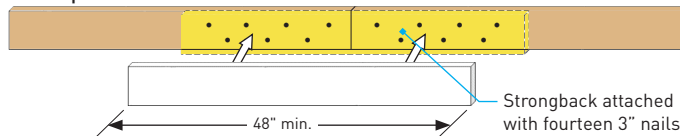

### Overlap option

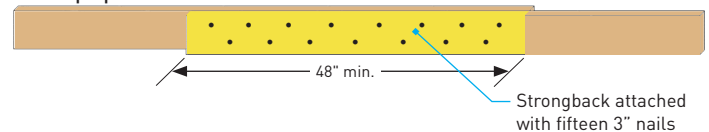

## STRONGBACK ATTACHMENT

Strongbacks need to be tightly connected to the perpendicular bearing walls to ensure their performance. Also, the strongbacks need to be attached, with no gap, to the Posi-Strut using three 3.25" nails or two 3" #8 screws.

**If unsure, or if a strongback has been damaged during construction, please contact your regional Posi-Strut manufacturer.**

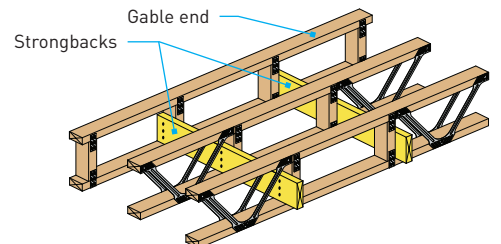

## ASSEMBLY DETAILS USING FTC FLOOR CLIPS

The following details are typical details. Special conditions or geometrical configurations may require an adjustment to the quantity and position of the FTC clips.

### Installation:

- Install the FTC clip using 10d x 1-1/2" long (0.148" dia. nails).
- Please review the tables to determine the quantity of FTC required to transfer the load.
- All FTC are to be installed within 12" of the concentrated load location.
- For higher transfer requirements, consult with the truss engineer.
- For specific details, please contact your Posi-Strut manufacturer.
- FTC clips shall be installed in pairs or multiples of two, symmetrical with respect to the location of the load.
- For additional information on connecting Posi-Strut two-ply girders, refer to the MiTek Structural Products Catalogue available on our website at [www.mitek.ca](http://www.mitek.ca).



typical FTC installation on Posi-Strut

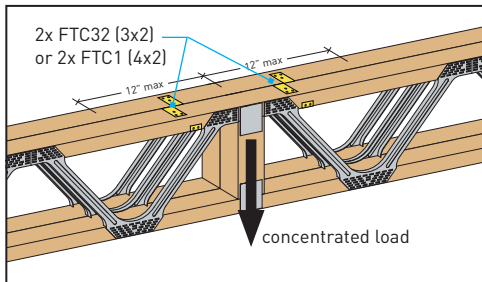

FTC CLIPS	LOAD TRANSFER (LBS)
2 FTC32 clips for 3x2 chords	1700
2 FTC1 clips for 4x2 chords	2160

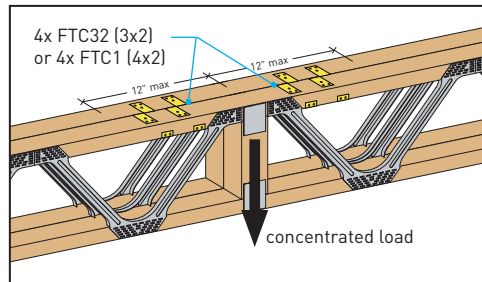

FTC CLIPS	LOAD TRANSFER (LBS)
4 FTC32 clips for 3x2 chords	3400
4 FTC1 clips for 4x2 chords	4320

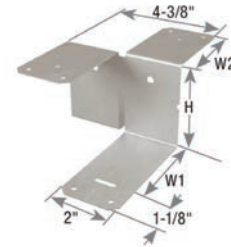

typical FTC load transfer clip

## ASSEMBLY DETAILS USING FlatLOK SCREWS

The following details are typical details. Special conditions or geometrical configurations may require an adjustment to the quantity and position of the FlatLOK screws.

### Installation:

- Using an impact driver or high torque 1/2" variable speed drill (minimum 18V if cordless), bring fastener flush with wood surface. Do not overdrive. No pre-drilling is required.
- All FlatLOK screws have to be installed on the top chord within 12" of the concentrated load location.
- **Do not install screws in bottom chord (or any other tension member) unless approved by the truss engineer.**
- Ensure a minimum 5" screw spacing parallel to grain.
- Do not drive screws through flanges of Posi-Strut webs. Drive screws directly into lumber.
- For higher transfer requirements, consult with the truss engineer.
- For additional information on connecting Posi-Strut two-ply girders, refer to the MiTek Structural Products Catalogue available on our website at [www.mitek.ca](http://www.mitek.ca).



typical FlatLOK screws

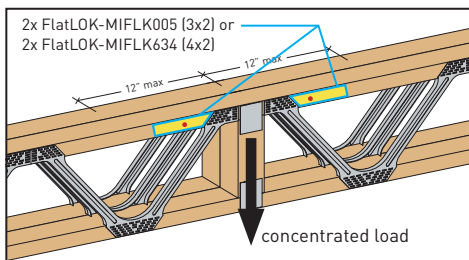

FlatLOK SCREWS PER CHORD	LOAD TRANSFER (LBS)
2x FlatLOK-MIFLK005 through 3x2 chords	1040
2x FlatLOK-MIFLK634 through 4x2 chords	1080

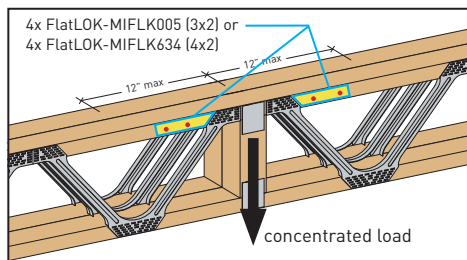

FlatLOK SCREWS PER CHORD	LOAD TRANSFER (LBS)
4x FlatLOK-MIFLK005 through 3x2 chords	2080
4x FlatLOK-MIFLK634 through 4x2 chords	2160

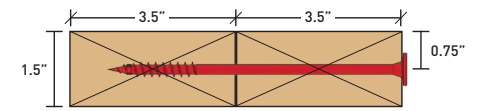
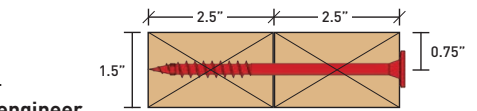

typical FlatLOK installation on Posi-Strut

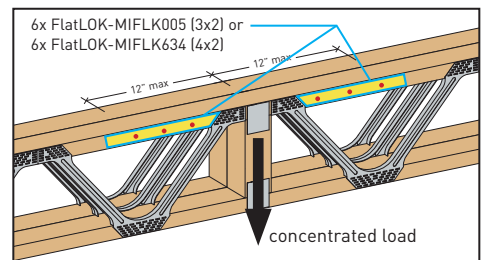

FlatLOK SCREWS PER CHORD	LOAD TRANSFER (LBS)
6x FlatLOK-MIFLK005 through 3x2 chords	3120
6x FlatLOK-MIFLK634 through 4x2 chords	3240



Division 06 – Wood, Plastics, and Composites  
06 17 00 Shop-Fabricated Structural Wood  
06 17 33 Wood I-Joists

Page 1 of 2

MiTek Canada Inc.  
Design No. MCI/WI 45-01  
Posi-Strut Metal Web System  
Floor/Ceiling Assembly  
ASTM-E119, CAN/ULC-S101, NFPA-251, UBC-7-1, UL 263  
Rating: 3/4 Hour – Unrestrained

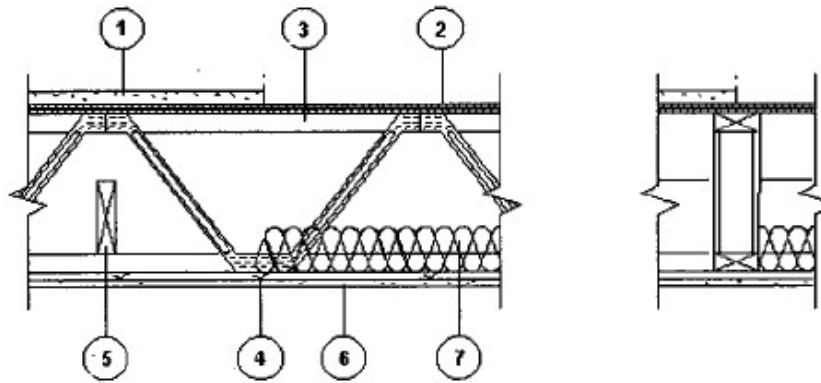

Finish Rating: 15 Minutes  
STC 50 with Insulation & Resilient Channels  
STC 55 with 1-1/2 in. of Lightweight Concrete

1. **TOPPING (Optional):** Subject to design and project limitations, these systems may be augmented with a lightweight floor topping mix containing perlite or vermiculite aggregate.
2. **FLOORING:** Min. 5/8 in. (15.9mm) plywood or O-2 grade waferboard or strandboard. See below for spacing >16 in. (400mm) on center (oc).

**SUB-FLOORING:** Sub-floor panels to conform to one of the following:

Max. Joists Spacing	Plywood & O-2 Grade Waferboard and Strandboard	Waferboard and Strandboard R-1 & O-1 Grade
16 in. (400mm)	5/8 in. (15.9mm)	5/8 in. (15.9mm)
19.2 in. (500mm)	3/4 in. (19.0mm)	3/4 in. (19.0mm)
24 in. (600mm)	3/4 in. (19.0mm)	3/4 in. (19.0mm)

**SUB-FLOORING FASTENING:** Min. length of fastener for sheathing and subfloor attachment for thickness from 5/8 in. (15.9mm) to 3/4 in. (19.0mm) thick is:

- A. Common or Spiral Nail – 2 in. (51mm) (Canada); 8d (0.131 in. dia. x 2.5 in. long) (US).
- B. Ring Thread Nail – 1-3/4 in. (45mm) (Canada); 6d (0.120 in. dia. x 2 in. long) (US).

Nail spacing shall be 6 in. (150mm) oc along butt edges of panel and 12 in. (300mm) (Canada) and 10 in. (US) oc along intermediate support.

**3. CERTIFIED MANUFACTURER:** MiTek Canada Inc.

**CERTIFIED PRODUCT:** MiTek Posi-Strut System

Listed fire designs are based on systems designed for structural and functional performance in accordance with MiTek Canada Inc. procedures. All designs are tested in unrestrained configuration. The chord materials are structural rated lumber material as graded under NLGA-1993



Division 06 – Wood, Plastics, and Composites  
06 17 00 Shop-Fabricated Structural Wood  
06 17 33 Wood I-Joists

Page 2 of 2

Standard Grading rules for Canadian Lumber or graded by an inspection bureau or agency approved by the United States Department of Commerce Board of Review of the American Lumber Standards Committee with chord sizes of 3 x 2, 4 x 2, 5 x 2.

**CERTIFIED MODELS:** MiTek Posi-Strut Series: Includes PS-10, PS-10V2, PS-12, PS-12V2, PS-12i, PS-13, PS-14, PS-14V3, PS-16, PS-16V3 metal webs having a min. depth of 9-1/4 in. and spaced up to a max. of 24 in. oc for floor/ceiling systems.

MiTek Canada Inc. Posi-Strut metal web system with structural graded chords as per NLGA grading rules. All Posi-Struts are to be designed and sealed by a Professional Engineer.

#### 4. FURRING CHANNELS (Optional)

**5. BRIDGING/STRONGBACK:** 2 x 6 SPF #2 to be attached to each bottom chord of the assembly with two 3 in. screws and to be spaced at 7 ft. oc.

**6. GYPSUM BOARD:** 5/8 in. Type X gypsum board to be screwed with 1-1/2 in. Type W screws and spaced 12 in. oc on intermediate joists and 6 in. oc on joist at butt joints. Max. width is 48 in. and all exposed joints are taped and finished with two additional coats of joint compound. Screw heads are covered with two coats of joint compound.

**7. INSULATION (Optional):** Where design requires insulation, it shall be 1-1/2 in. (38mm) thick mineral wool insulation batts.

Where insulation is optional, it may be 3-1/2 in. (89mm) thick fiberglass insulation batts with density 0.75 lb/cu.ft. All batts are to be placed between bottom joist flanges and supported by metal furring channels. All butt joints shall be over furring channels.

**8. SUSPENDED CEILING SYSTEM (Optional, Not Shown):** Any suspended ceiling system may be selected which satisfies the following criteria:

- A. It must be a fire rated system, and be installed within the terms of its listing.
- B. In lieu of a finish rating, any suspended ceiling design may be used that is part of a listed assembly, utilizing a wood deck and wood framing, that has a fire resistance rating equal to or greater than the rating assigned to the MiTek Canada, Inc. assembly.
- C. It must be suspended in accordance with the terms of its listing and a min. of 7-1/2 in. below the joist.
- D. Penetrations such as ducts, air diffusers, and fixtures must be protected in such a manner as to conform to the terms of the listing of the suspended ceiling system.



Division 06 – Wood, Plastics, and Composites  
06 17 00 Shop-Fabricated Structural Wood  
06 17 33 Wood I-Joists

Page 1 of 2

**MiTek Canada Inc.**  
**Design No. MCI/WI 45-03**  
**Posi-Strut Metal Web System**  
**Floor/Suspended Ceiling Assembly**  
**ASTM-E119, CAN/ULC-S101, NFPA-251, UBC-7-1, UL 263**  
**Rating: 3/4 Hour – Unrestrained**

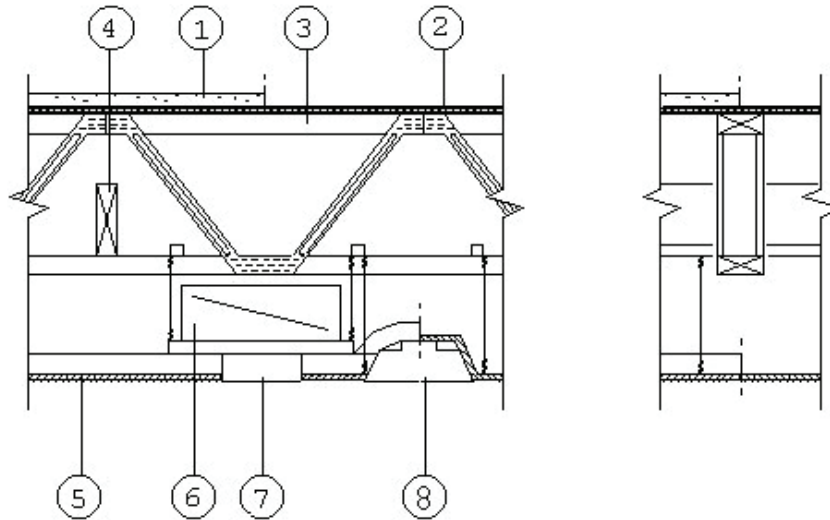

Finish Rating: 22 Minutes

**1. TOPPING (Optional):** Subject to design and project limitations, these systems may be augmented with a lightweight floor topping mix containing perlite or vermiculite aggregate.

**2. FLOORING:** Min. 5/8 in. (15.9mm) plywood or O-2 grade waferboard or strandboard. See below for spacing >16 in. (400mm) on center (oc).

**SUB-FLOORING:** Sub-floor panels to conform to one of the following:

Max. Joists Spacing	Plywood & O-2 Grade Waferboard and Strandboard	Waferboard and Strandboard R-1 & O-1 Grade
16 in. (400mm)	5/8 in. (15.9mm)	5/8 in. (15.9mm)
19.2 in. (500mm)	3/4 in. (19.0mm)	3/4 in. (19.0mm)
24 in. (600mm)	3/4 in. (19.0mm)	3/4 in. (19.0mm)

**SUB-FLOORING FASTENING:** Min. length of fastener for sheathing and subfloor

attachment for thickness from 5/8 in. (15.9mm) to 3/4 in. (19.0mm) thick is:

- A. Common or Spiral Nail – 2 in. (51mm) (Canada); 8d (0.131 in. dia. x 2.5 in. long) (US).
- B. Ring Thread Nail – 1-3/4 in. (45mm) (Canada); 6d (0.120 in. dia. x 2 in. long) (US).

Nail spacing shall be 6 in. (150mm) oc along butt edges of panel and 12 in. (300mm) (Canada) and 10 in. (US) oc along intermediate support.

**3. CERTIFIED MANUFACTURER:** MiTek Canada Inc.

**CERTIFIED PRODUCT:** MiTek Posi-Strut System

Division 06 – Wood, Plastics, and Composites  
06 17 00 Shop-Fabricated Structural Wood  
06 17 33 Wood I-Joists

Page 2 of 2

Listed fire designs are based on systems designed for structural and functional performance in accordance with MiTek Canada Inc. procedures. All designs are tested in unrestrained configuration. The chord materials are structural rated lumber material as graded under NLGA-1993 Standard Grading rules for Canadian Lumber or graded by an inspection bureau or agency approved by the United States Department of Commerce Board of Review of the American Lumber Standards Committee with chord sizes of 3 x 2, 4 x 2, 5 x 2.

**CERTIFIED MODELS:** MiTek Posi-Strut Series: Includes PS-10, PS-10V2, PS-12, PS-12V2, PS-12i, PS-13, PS-14, PS-14V3, PS-16, PS-16V3 metal webs having a min. depth of 9-1/4 in. and spaced up to a max. of 24 in. oc for floor/ceiling systems.

MiTek Canada Inc. Posi-Strut metal web system with structural graded chords as per NLGA grading rules. All Posi-Struts are to be designed and sealed by a Professional Engineer.

4. **BRIDGING/STRONGBACK:** 2 x 6 SPF #2 to be screwed to the bottom chord with two 3 in. screws and to be spaced at 7 ft. oc.
5. **CEILING SYSTEM:** Suitable fire rated suspended ceiling system which satisfies the following criteria:
  - A. Any suspended ceiling design may be used that is part of a listed assembly, utilizing a wood deck and wood framing, that has a fire resistance rating equal to or greater than the rating assigned to the MiTek Canada, Inc. assembly.
  - B. It must be suspended in accordance with the terms of its listing and a min. of 7-1/2 in. below the joist.
  - C. Penetrations such as ducts, air diffusers, and fixtures must be protected in such a manner as to conform to the terms of the listing of the suspended ceiling system.
6. **DUCT:** See Item 5.
7. **AIR DIFFUSER:** See Item 5.
8. **FIXTURES:** See Item 5.
9. **INSULATION (Optional):** Where design requires insulation, it shall be 1-1/2 in. (38mm) thick mineral wool insulation batts. Where insulation is optional, it may be 3-1/2 in. (89mm) thick fiberglass insulation batts with density 0.75 lb/cu.ft. All batts are to be placed between bottom joist flanges and supported by metal furring channels. All butt joints shall be over furring channels.



Division 06 – Wood, Plastics, and Composites  
06 17 00 Shop-Fabricated Structural Wood  
06 17 33 Wood I-Joists

Page 1 of 2

**MiTek Canada Inc.**  
**Design No. MCI/WI 60-01**  
**Posi-Strut Metal Web System**  
**Floor/Ceiling Assembly**  
**ASTM-E119, CAN/ULC-S101, NFPA-251, UBC-7-1, UL 263**  
**Rating: 1 Hour – Unrestrained**

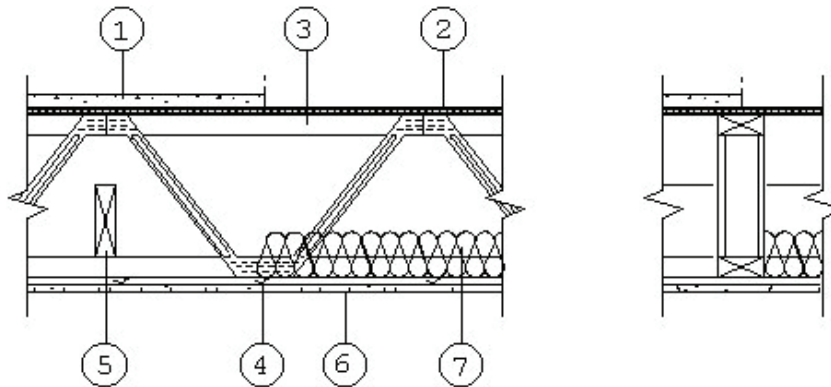

Finish Rating: 22 Minutes  
STC 50 with Insulation & Resilient Channels  
STC 55 with 1-1/2 in. of Lightweight Concrete

- 1. TOPPING (Optional):** Subject to design and project limitations, these systems may be augmented with a lightweight floor topping mix containing perlite or vermiculite aggregate.
- 2. FLOORING:** Min. 5/8 in. (15.9mm) plywood or O-2 grade waferboard or strandboard. See below for spacing >16 in. (400mm) on center (oc).

**SUB-FLOORING:** Sub-floor panels to conform to one of the following:

Max. Joists Spacing	Plywood & O-2 Grade Waferboard and Strandboard	Waferboard and Strandboard R-1 & O-1 Grade
16 in. (400mm)	5/8 in. (15.9mm)	5/8 in. (15.9mm)
19.2 in. (500mm)	3/4 in. (19.0mm)	3/4 in. (19.0mm)
24 in. (600mm)	3/4 in. (19.0mm)	3/4 in. (19.0mm)

**SUB-FLOORING FASTENING:** Min. length of fastener for sheathing and subfloor attachment for thickness from 5/8 in. (15.9mm) to 3/4 in. (19.0mm) thick is:

- A. Common or Spiral Nail – 2 in. (51mm) (Canada); 8d (0.131 in. dia. x 2.5 in. long) (US).
- B. Ring Thread Nail – 1-3/4 in. (45mm) (Canada); 6d (0.120 in. dia. x 2 in. long) (US).

Nail spacing shall be 6 in. (150mm) oc along butt edges of panel and 12 in. (300mm) (Canada) and 10 in. (US) oc along intermediate support.

**3. CERTIFIED MANUFACTURER:** MiTek Canada Inc.

**CERTIFIED PRODUCT:** MiTek Posi-Strut System

Listed fire designs are based on systems designed for structural and functional performance in accordance with MiTek Canada Inc. procedures. All designs are tested in unrestrained configuration. The chord materials are structural rated lumber material as graded under NLGA-1993

Division 06 – Wood, Plastics, and Composites  
 06 17 00 Shop-Fabricated Structural Wood  
 06 17 33 Wood I-Joists

Page 2 of 2

Standard Grading rules for Canadian Lumber or graded by an inspection bureau or agency approved by the United States Department of Commerce Board of Review of the American Lumber Standards Committee with chord sizes of 3 x 2, 4 x 2, 5 x 2.

**CERTIFIED MODELS:** MiTek Posi-Strut Series: Includes PS-10, PS-10V2, PS-12, PS-12V2, PS-12i, PS-13, PS-14, PS-14V3, PS-16, PS-16V3 metal webs having a min. depth of 9-1/4 in. and spaced up to a max. of 24 in. oc for floor/ceiling systems.

MiTek Canada Inc. Posi-Strut metal web system with structural graded chords as per NLGA grading rules. All Posi-Struts are to be designed and sealed by a Professional Engineer.

**4. FURRING CHANNELS (Resilient Channels):** 7/8 in. deep with 26 GA galvanized steel wired to underside of each truss with double strands of 18 GA steel tie wire or screwed to each truss with 1-1/4 in. Type S drywall screws. Double rows of furring channels at each gypsum wallboard joist (at least 3 in. apart). Alternate: Min. 25 GA 1/2 in. offset resilient channels screwed to each truss with 1-1/4 in. Type S drywall screws.

**5. BRIDGING/STRONGBACK:** 2 x 6 SPF #2 to be screwed to the bottom chord with two 3 in. screws and to be spaced at 7 ft. oc.

**6. GYPSUM BOARD:** 4 ft. x 10 ft. x 5/8 in. Type C (listed Firecode C or Westroc Fireboard C) with edges running perpendicular to the furring channels. Screwed to channels with 1-1/4 in. Type S

bugle-head drywall screws set at 12 in. oc and 1-1/2 in. from edges of board (min.). All joints to be taped. Joints and screw heads covered with 2 layers of gyproc joint filler.

**7. INSULATION (Optional):** Where design requires insulation, it shall be 1-1/2 in. (38mm) thick mineral wool insulation batts. Where insulation is optional, it may be 3-1/2 in. (89mm) thick fiberglass insulation batts with density 0.75 lb/cu.ft. All batts are to be placed between bottom joist flanges and supported by metal furring channels. All butt joints shall be over furring channels.

**8. SUSPENDED CEILING SYSTEM (Optional, Not Shown):** Any suspended ceiling system may be selected which satisfies the following criteria:

- A. It must be a fire rated system, and be installed within the terms of its listing.
- B. In lieu of a finish rating, any suspended ceiling design may be used that is part of a listed assembly, utilizing a wood deck and wood framing, that has a fire resistance rating equal to or greater than the rating assigned to the MiTek Canada, Inc. assembly.
- C. It must be suspended in accordance with the terms of its listing and a min. of 7-1/2 in. below the joist.
- D. Penetrations such as ducts, air diffusers, and fixtures must be protected in such a manner as to conform to the terms of the listing of the suspended ceiling system.



Division 06 – Wood, Plastics, and Composites  
06 17 00 Shop-Fabricated Structural Wood  
06 17 33 Wood I-Joists

Page 1 of 2

MiTek Canada Inc.  
Design No. MCI/WI 60-03  
Posi-Strut Metal Web System  
Floor/Suspended Ceiling Assembly  
ASTM-E119, CAN/ULC-S101, NFPA-251, UBC-7-1, UL 263  
Rating: 1 Hour – Unrestrained

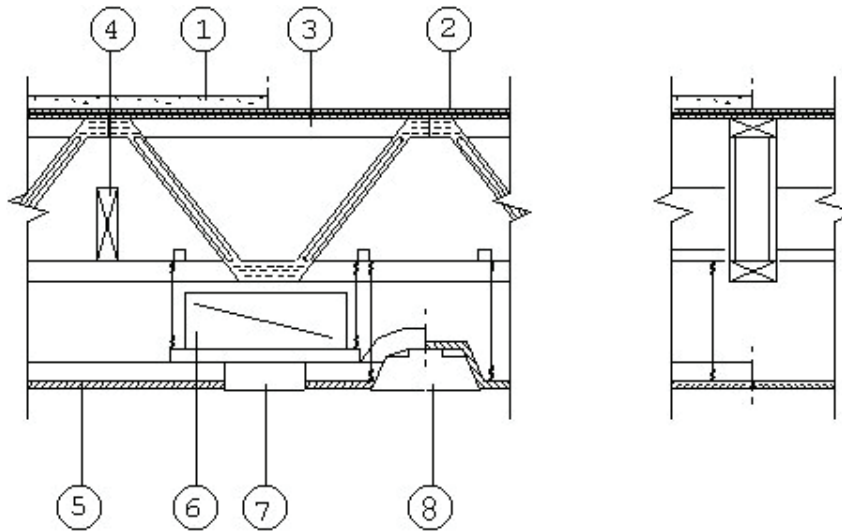

Finish Rating: 27 Minutes

**1. TOPPING (Optional):** Subject to design and project limitations, these systems may be augmented with a lightweight floor topping mix containing perlite or vermiculite aggregate.

**2. FLOORING:** Min. 5/8 in. (15.9mm) plywood or O-2 grade waferboard or strandboard. See below for spacing >16 in. (400mm) on center (oc).

**SUB-FLOORING:** Sub-floor panels to conform to one of the following:

Max. Joists Spacing	Plywood & O-2 Grade Waferboard and Strandboard	Waferboard and Strandboard R-1 & O-1 Grade
16 in. (400mm)	5/8 in. (15.9mm)	5/8 in. (15.9mm)
19.2 in. (500mm)	3/4 in. (19.0mm)	3/4 in. (19.0mm)
24 in. (600mm)	3/4 in. (19.0mm)	3/4 in. (19.0mm)

**SUB-FLOORING FASTENING:** Min. length of fastener for sheathing and subfloor

attachment for thickness from 5/8 in. (15.9mm) to 3/4 in. (19.0mm) thick is:

- A. Common or Spiral Nail – 2 in. (51mm) (Canada); 8d (0.131 in. dia. x 2.5 in. long) (US).
- B. Ring Thread Nail – 1-3/4 in. (45mm) (Canada); 6d (0.120 in. dia. x 2 in. long) (US).

Nail spacing shall be 6 in. (150mm) oc along butt edges of panel and 12 in. (300mm) (Canada) and 10 in. (US) oc along intermediate support.

**3. CERTIFIED MANUFACTURER:** MiTek Canada Inc.

**CERTIFIED PRODUCT:** MiTek Posi-Strut System

Division 06 – Wood, Plastics, and Composites  
06 17 00 Shop-Fabricated Structural Wood  
06 17 33 Wood I-Joists

Page 2 of 2

Listed fire designs are based on systems designed for structural and functional performance in accordance with MiTek Canada Inc. procedures. All designs are tested in unrestrained configuration. The chord materials are structural rated lumber material as graded under NLGA-1993 Standard Grading rules for Canadian Lumber or graded by an inspection bureau or agency approved by the United States Department of Commerce Board of Review of the American Lumber Standards Committee with chord sizes of 3 x 2, 4 x 2, 5 x 2.

**CERTIFIED MODELS:** MiTek Posi-Strut Series: Includes PS-10, PS-10V2, PS-12, PS-12V2, PS-12i, PS-13, PS-14, PS-14V3, PS-16, PS-16V3 metal webs having a min. depth of 9-1/4 in. and spaced up to a max. of 24 in. oc for floor/ceiling systems.

MiTek Canada Inc. Posi-Strut metal web system with structural graded chords as per NLGA grading rules. All Posi-Struts are to be designed and sealed by a Professional Engineer.

4. **BRIDGING/STRONGBACK:** 2 x 6 SPF #2 to be screwed to the bottom chord with two 3 in. screws and to be spaced at 7 ft. oc.
5. **CEILING SYSTEM:** Suitable fire rated suspended ceiling system which satisfies the following criteria:

- A. Any suspended ceiling design may be used that is part of a listed assembly, utilizing a wood deck and wood framing, that has a fire resistance rating equal to or greater than the rating assigned to the MiTek Canada, Inc. assembly.
- B. It must be suspended in accordance with the terms of its listing and a min. of 7-1/2 in. below the joist.
- C. Penetrations such as ducts, air diffusers, and fixtures must be protected in such a manner as to conform to the terms of the listing of the suspended ceiling system.

6. **DUCT:** See Item 5.

7. **AIR DIFFUSER:** See Item 5.

8. **FIXTURES:** See Item 5.

9. **INSULATION (Optional):** Where design requires insulation, it shall be 1-1/2 in. (38mm) thick mineral wool insulation batts. Where insulation is optional, it may be 3-1/2 in. (89mm) thick fiberglass insulation batts with density 0.75 lb/cu.ft. All batts are to be placed between bottom joist flanges and supported by metal furring channels. All butt joints shall be over furring channels.



Division 06 – Wood, Plastics, and Composites  
06 17 00 Shop-Fabricated Structural Wood  
06 17 33 Wood I-Joists

Page 1 of 2

MiTek Canada Inc.  
Design No. MCI/WI 90-01  
Posi-Strut Metal Web System  
Floor/Ceiling Assembly  
ASTM-E119, CAN/ULC-S101, NFPA-251, UBC-7-1, UL 263  
Rating: 1-1/2 Hour – Unrestrained

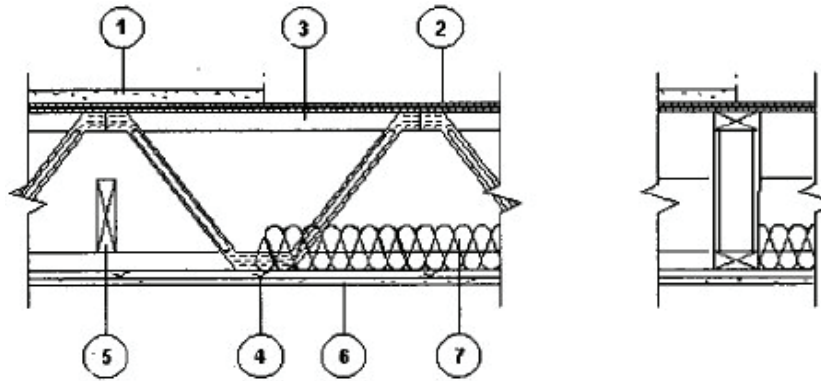

Finish Rating: 45 Minutes  
STC 52 with Insulation & Resilient Channels  
STC 57 with 1-1/2 in. of Lightweight Concrete

- 1. TOPPING (Optional):** Subject to design and project limitations, these systems may be augmented with a lightweight floor topping mix containing perlite or vermiculite aggregate.
- 2. FLOORING:** Min. 5/8 in. (15.9mm) plywood or O-2 grade waferboard or strandboard. See below for spacing >16 in. (400mm) on center (oc).

**SUB-FLOORING:** Sub-floor panels to conform to one of the following:

Max. Joists Spacing	Plywood & O-2 Grade Waferboard and Strandboard	Waferboard and Strandboard R-1 & O-1 Grade
16 in. (400mm)	5/8 in. (15.9mm)	5/8 in. (15.9mm)
19.2 in. (500mm)	3/4 in. (19.0mm)	3/4 in. (19.0mm)
24 in. (600mm)	3/4 in. (19.0mm)	3/4 in. (19.0mm)

**SUB-FLOORING FASTENING:** Min. length of fastener for sheathing and subfloor attachment for thickness from 5/8 in. (15.9mm) to 3/4 in. (19.0mm) thick is:

- Common or Spiral Nail – 2 in. (51mm) (Canada); 8d (0.131 in. dia. x 2.5 in. long) (US).
- Ring Thread Nail – 1-3/4 in. (45mm) (Canada); 6d (0.120 in. dia. x 2 in. long) (US).

Nail spacing shall be 6 in. (150mm) oc along butt edges of panel and 12 in. (300mm) (Canada) and 10 in. (US) oc along intermediate support.

**3. CERTIFIED MANUFACTURER:** MiTek Canada Inc.

**CERTIFIED PRODUCT:** MiTek Posi-Strut System

Listed fire designs are based on systems designed for structural and functional performance in accordance with MiTek Canada Inc. procedures. All designs are tested in unrestrained configuration. The chord materials are structural rated lumber material as graded under NLGA-1993



Division 06 – Wood, Plastics, and Composites  
06 17 00 Shop-Fabricated Structural Wood  
06 17 33 Wood I-Joists

Page 2 of 2

Standard Grading rules for Canadian Lumber or graded by an inspection bureau or agency approved by the United States Department of Commerce Board of Review of the American Lumber Standards Committee with chord sizes of 3 x 2, 4 x 2, 5 x 2.

**CERTIFIED MODELS:** MiTek Posi-Strut Series: Includes PS-10, PS-10V2, PS-12, PS-12V2, PS-12i, PS-13, PS-14, PS-14V3, PS-16, PS-16V3 metal webs having a min. depth of 9-1/4 in. and spaced up to a max. of 24 in. oc for floor/ceiling systems.

MiTek Canada Inc. Posi-Strut metal web system with structural graded chords as per NLGA grading rules. All Posi-Struts are to be designed and sealed by a Professional Engineer.

#### 4. FURRING CHANNELS (Optional)

5. **BRIDGING/STRONGBACK:** 2 x 6 SPF #2 to be screwed to the bottom chord with two 3 in. screws and to be spaced at 7 ft. oc.

6. **GYPSUM BOARD:** Two layers of 5/8 in. Type X thick gypsum wallboard. Base layer to be installed with long dimensions perpendicular to supports with end joints butted over supports and staggered 24 in. min. 1-1/4 in. Type W screws are spaced 12 in. oc on intermediate supports and 6 in. oc on supports at butt joints. Face layer installed with long dimension perpendicular to supports and edges staggered 24 in. from base layer end joints. 2-1/4 in. Type W screws are placed min. 12 in. oc on intermediate supports and 8 in. oc on end supports at butt joints. To fasten face layer to base layer, a row of Type G screws is located 6 in. away from end joints, spaced 8 in. oc.

7. **INSULATION (Optional):** Where design requires insulation, it shall be 1-1/2 in. (38mm) thick mineral wool insulation batts. Where insulation is optional, it may be 3-1/2 in. (89mm) thick fiberglass insulation batts with density 0.75 lb/cu.ft. All batts are to be placed between bottom joist flanges and supported by metal furring channels. All butt joints shall be over furring channels.

8. **SUSPENDED CEILING SYSTEM (Optional, Not Shown):** Any suspended ceiling system may be selected which satisfies the following criteria:

- A. It must be a fire rated system, and be installed within the terms of its listing.
- B. In lieu of a finish rating, any suspended ceiling design may be used that is part of a listed assembly, utilizing a wood deck and wood framing, that has a fire resistance rating equal to or greater than the rating assigned to the MiTek Canada, Inc. assembly.
- C. It must be suspended in accordance with the terms of its listing and a min. of 7-1/2 in. below the joist.
- D. Penetrations such as ducts, air diffusers, and fixtures must be protected in such a manner as to conform to the terms of the listing of the suspended ceiling system.



Division 06 – Wood, Plastics, and Composites  
06 17 00 Shop-Fabricated Structural Wood  
06 17 33 Wood I-Joists

Page 1 of 2

MiTek Canada Inc.  
Design No. MCI/WI 90-02  
Metal Truss Plates  
Floor/Ceiling Assembly  
ASTM-E119, CAN/ULC-S101, NFPA-251, UBC-7-1, UL 263  
Rating: 1-1/2 Hour – Unrestrained

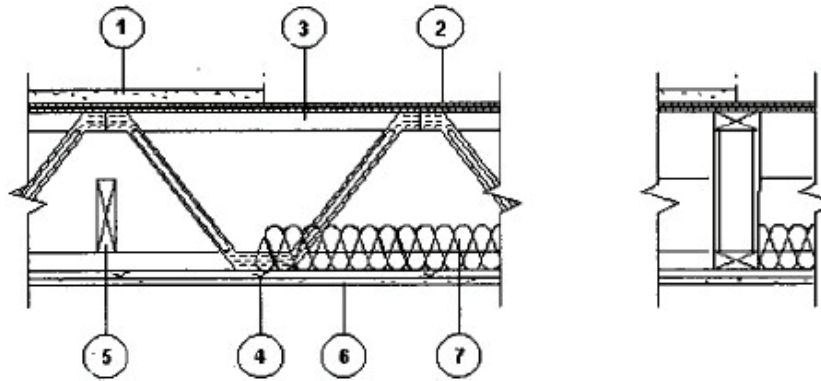

Finish Rating: 45 Minutes  
STC 53 with Insulation & Resilient Channels  
STC 57 with 1-1/2 in. of Lightweight Concrete

- 1. TOPPING (Optional):** Subject to design and project limitations, these systems may be augmented with a lightweight floor topping mix containing perlite or vermiculite aggregate.
- 2. FLOORING:** Min. 5/8 in. (15.9mm) plywood or O-2 grade waferboard or strandboard. See below for spacing >16 in. (400mm) on center (oc).

**SUB-FLOORING:** Sub-floor panels to conform to one of the following:

Max. Joists Spacing	Plywood & O-2 Grade Waferboard and Strandboard	Waferboard and Strandboard R-1 & O-1 Grade
16 in. (400mm)	5/8 in. (15.9mm)	5/8 in. (15.9mm)
19.2 in. (500mm)	3/4 in. (19.0mm)	3/4 in. (19.0mm)
24 in. (600mm)	3/4 in. (19.0mm)	3/4 in. (19.0mm)

**SUB-FLOORING FASTENING:** Min. length of fastener for sheathing and subfloor attachment for thickness from 5/8 in. (15.9mm) to 3/4 in. (19.0mm) thick is:

- Common or Spiral Nail – 2 in. (51mm) (Canada); 8d (0.131 in. dia. x 2.5 in. long) (US).
- Ring Thread Nail – 1-3/4 in. (45mm) (Canada); 6d (0.120 in. dia. x 2 in. long) (US).

Nail spacing shall be 6 in. (150mm) oc along butt edges of panel and 12 in. (300mm) (Canada) and 10 in. (US) oc along intermediate support.

**3. CERTIFIED MANUFACTURER:** MiTek Canada Inc.

**CERTIFIED PRODUCT:** MiTek Metal Truss Plates

Listed fire designs are based on systems designed for structural and functional performance in accordance with MiTek Canada Inc. procedures. All designs are tested in unrestrained configuration. The chord materials are structural rated lumber material as graded under NLGA-1993

Division 06 – Wood, Plastics, and Composites  
06 17 00 Shop-Fabricated Structural Wood  
06 17 33 Wood I-Joists

Page 2 of 2

Standard Grading rules for Canadian Lumber or graded by an inspection bureau or agency approved by the United States Department of Commerce Board of Review of the American Lumber Standards Committee with chord sizes of 3 x 2, 4 x 2, 5 x 2.

**CERTIFIED MODELS:** Includes wood web floor truss designs with metal truss plates manufactured by MiTek Canada Inc. having a min. depth of 10 in. and spaced up to max. of 24 in. oc for floor/ceiling systems.

MiTek Canada Inc. Metal Truss Plates with structural graded chords as per NLGA grading rules. All floor trusses are to be designed and sealed by a Professional Engineer.

#### 4. FURRING CHANNELS (Optional)

**5. BRIDGING/STRONGBACK:** 2 x 6 SPF #2 to be screwed to the bottom chord with two 3 in. screws and to be spaced at 7 ft. oc.

**6. GYPSUM BOARD:** Two layers of 5/8 in. Type X thick gypsum wallboard. Base layer to be installed with long dimensions perpendicular to supports with end joints butted over supports and staggered 24 in. min. 1-1/4 in. Type W screws are spaced 12 in. oc on intermediate supports and 6 in. oc on supports at butt joints. Face layer installed with long dimension perpendicular to supports and edges staggered 24 in. from base layer end joints. 2-1/4 in. Type W screws are placed min. 12 in. oc on intermediate supports and 8 in. oc on end supports at butt joints. To fasten face layer to base layer, a row of Type G screws is located 6 in. away from end joints, spaced 8 in. oc.

**7. INSULATION (Optional):** Where design requires insulation, it shall be 1-1/2 in. (38mm) thick mineral wool insulation batts. Where insulation is optional, it may be 3-1/2 in. (89mm) thick fiberglass insulation batts with density 0.75 lb/cu.ft. All batts are to be placed between bottom joist flanges and supported by metal furring channels. All butt joints shall be over furring channels.

**8. SUSPENDED CEILING SYSTEM (Optional, Not Shown):** Any suspended ceiling system may be selected which satisfies the following criteria:

- A. It must be a fire rated system, and be installed within the terms of its listing.
- B. In lieu of a finish rating, any suspended ceiling design may be used that is part of a listed assembly, utilizing a wood deck and wood framing, that has a fire resistance rating equal to or greater than the rating assigned to the MiTek Canada, Inc. assembly.
- C. It must be suspended in accordance with the terms of its listing and a min. of 7-1/2 in. below the joist.
- D. Penetrations such as ducts, air diffusers, and fixtures must be protected in such a manner as to conform to the terms of the listing of the suspended ceiling system.

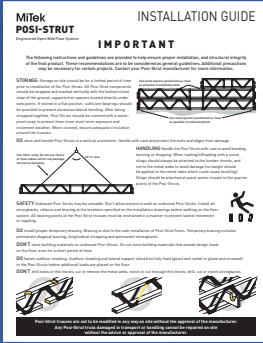

## Installation Guide

Developed for job site usage, containing all the important installation information and instructions.

[www.mitek.ca/Posi-Strut/Resources/Posi-Strut-Engineered-System/Installation guide](http://www.mitek.ca/Posi-Strut/Resources/Posi-Strut-Engineered-System/Installation%20guide)

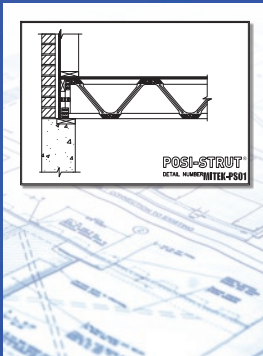

## CAD details

A series of CAD details are available for construction professionals. Free to download at:

[www.mitek.ca/Posi-Strut/Resources/Posi-Strut-Engineered-System/CAD details](http://www.mitek.ca/Posi-Strut/Resources/Posi-Strut-Engineered-System/CAD%20details)



## MiTek® Structural Products Catalogue APP

Our entire catalogue at your finger tips with easy navigation to search structural connector products. Access product applications, instructions, fastening schedules, load ratings and reference numbers. Cross reference product specifications and look up information on the fly. Email pages from the app on any mobile device. Free download on the Apple App Store, the Microsoft Store and on Google Play. Learn more at:

[Mitek.ca/software/Product-Catalogue-App](http://Mitek.ca/software/Product-Catalogue-App)



## SAPHIRE™ Viewer - Available on 3 platforms

A free tool that brings home builders and building material suppliers together in a virtual job site review. From ridge line to foundation, SAPHIRE™ Viewer delivers great collaboration for design, approval, and on-site construction of your structural framing. Starting with a 3D BIM model provided by the material supplier(s) and component manufacturer.

Free download:

Apple App Store (Mobile App)

Google Play Store (Mobile App)

[Mitek.ca/software/SAPHIRE-Viewer](http://Mitek.ca/software/SAPHIRE-Viewer) (Desktop version)

